

Safety Standards

of the
Nuclear Safety Standards Commission (KTA)

KTA 3905 (6/99) (incl. rectification of 7/00)

Load Attaching Points on Loads in Nuclear Power Plants

(Lastanschlagpunkte an Lasten in Kernkraftwerken)

A previous version of this Safety Standard
was issued 6/94

If there is any doubt regarding the information contained in this translation, the German wording shall apply.

Editor:

KTA-Geschaeftsstelle c/o Bundesamt fuer Strahlenschutz (BfS)
Willy-Brandt-Strasse 5 • 38226 Salzgitter • Germany
Telephone +49-5341/885-(0) 901 • Telefax +49-5341/885-905

KTA SAFETY STANDARD

June 1999

Load Attaching Points on Loads in Nuclear Power Plants

KTA 3905

CONTENTS

<p>Fundamentals 5</p> <p>1 Scope 5</p> <p>2 Definitions 5</p> <p>3 General provisions 5</p> <p>4 Special provisions 5</p> <p>4.1 Classification 5</p> <p>4.2 Load attaching points with additional requirements 5</p> <p>4.3 Load attaching points with increased requirements 5</p> <p>4.4 Load attaching points on core components 6</p> <p>5 Analytical and structural design 6</p> <p>5.1 General 6</p> <p>5.2 Structural steel components 6</p> <p>5.3 Lifting lugs, bolts, tie rods and similar components 7</p> <p>5.4 Bolted connections 8</p> <p>5.5 Application of loads into structural concrete components 9</p> <p>5.6 Ropes and chains 9</p> <p>5.7 Core components 9</p> <p>6 Materials 10</p> <p>6.1 Selection of Materials 10</p> <p>6.2 Testing of materials 10</p> <p>6.3 Materials identification marking 10</p> <p>7 Design approval 10</p> <p>7.1 Required documents 10</p> <p>7.2 Procedure 12</p> <p>7.3 Certification of design approval 12</p> <p>8 Final inspection 12</p> <p>8.1 Load attaching points in acc. with clause 1 (1) 12</p> <p>8.2 Load attaching points in acc. with clause 1 (2) 12</p> <p>9 Acceptance test 13</p> <p>9.1 Load attaching points in acc. with clause 1 (1) 13</p> <p>9.2 Load attaching points in acc. with clause 1 (2) 13</p>	<p>10 In-service inspections 13</p> <p>10.1 Load attaching points in acc. with clause 1 (1) 13</p> <p>10.2 Load attaching points in acc. with clause 1 (2) 13</p> <p>11 Operation and maintenance 13</p> <p>11.1 Load attaching points in acc. with clause 1 (1) 13</p> <p>11.2 Load attaching points in acc. with clause 1 (2) 14</p> <p>12 Documentation 14</p> <p>12.1 General 14</p> <p>12.2 Compilation of documents 14</p> <p>12.3 Procedure of documentation 14</p> <p>Annex A: Materials test sheets (WPB) 18</p> <p>Annex B: Non-destructive testing (NDT) 36</p> <p>Annex C: Graphical representation of the delimitation between load attaching point and load for several examples 44</p> <p>Annex D: Examples for the classification of load attaching points 47</p> <p>Annex E: Stress number diagrams for analysis of cyclic operation and endurance strength 48</p> <p>Annex F: Stress number diagrams for analysis of cyclic operation and endurance strength of the materials 1.4541, 1.4306 and 1.4571 in accordance with DIN 17 440 49</p> <p>Annex G: Regulations and literature referred to in this Safety Standard 54</p> <p>Annex H: Changes with respect to the edition 6/94 and explanations (informative) 57</p>
---	---

PLEASE NOTE: Only the original German version of this safety standard represents the joint resolution of the 50-member Nuclear Safety Standards Commission (Kerntechnischer Ausschuss, KTA). The German version was made public in Bundesanzeiger No. 200a on October 22, 1999. Copies may be ordered through the Carl Heymanns Verlag KG, Luxemburger Str. 449, 50939 Koeln (Telefax +49-221-94373-603).

All questions regarding this English translation should please be directed to:

KTA-Geschaeftsstelle c/o BfS, Willy-Brandt-Strasse 5, 38226 Salzgitter, Germany

Comments by the editor:

Taking into account the meaning and usage of auxiliary verbs in the German language, in this translation the following agreements are effective:

- shall** indicates a mandatory requirement,
- shall basically** is used in the case of mandatory requirements to which specific exceptions (and only those!) are permitted. It is a requirement of the KTA that these exceptions - other than those in the case of **shall normally** - are specified in the text of the safety standard,
- shall normally** indicates a requirement to which exceptions are allowed. However, the exceptions used, shall be substantiated during the licensing procedure,
- should** indicates a recommendation or an example of good practice,
- may** indicates an acceptable or permissible method within the scope of this safety standard.

Fundamentals

(1) The safety standards of the Nuclear Safety Standards Commission (KTA) have the task of specifying those safety related requirements which shall be met with regard to precautions to be taken in accordance with the state of science and technology against the damage arising from the construction and operation of the facility (Sec. 7 para 2 subpara 3 Atomic Energy Act) in order to attain the protection goals specified in the Atomic Energy Act and the Radiological Protection Ordinance (StrlSchV) and which are further detailed in the "Safety Criteria for Nuclear Power Plants" and in the "Guidelines for the Assessment of the Design of PWR Nuclear Power Plants against Incidents pursuant to Sec. 28 para 3 of the Radiological Protection Ordinance (StrlSchV) - Incident Guidelines".

(2) The requirements to be derived from the above are specified in this safety standard for load attaching points. Regarding the danger potential

- a) general provisions or
- b) additional requirements to the general provisions or
- c) increased requirements exceeding the general provisions shall be taken into account for load attaching points.

(3) This safety standard deals with the design and analysis, materials, tests and inspections, operation and maintenance including documentation of load attaching points functioning as connecting element between load suspension device and load.

(4) Special requirements specific to a component are not dealt with here, but shall be taken into account where required.

1 Scope

(1) This safety standard shall apply to load attaching points on loads which are handled in nuclear power plants during specified normal operation and must comply with the special provisions of Section 4.

(2) This safety standard shall apply to load attaching points of the following core components:

- a) fuel elements, control elements and in-core instrumentation lances for pressurized water reactors,
- b) fuel elements, control rods and fuel assembly channels for boiling water reactors

(3) Load attaching points on core component encapsulations are to be considered load attaching points on core components.

(4) This safety standard does not apply to:

- a) load attaching points on reactor pressure vessel internals

Note:

Load attaching points on reactor pressure vessel internals are covered by KTA 3204.

- b) load attaching points on containers for the storage, handling and internal transport of radioactive substances, which meet the requirements of KTA 3604.

2 Definitions

(1) Load attaching point (LAP)

The load attaching point is the connecting element between load suspension device and load and is either

- a) an integral part of the load or
- b) bolted on or
- c) welded on or

- d) anchored in the concrete in the case of structural concrete components

Note:

The delimitation between load attaching point and load is described in Annex C with reference to examples.

(2) Authorized inspectors

Authorized inspectors for the tests and inspections for the purpose of this safety standard are the following on the basis of nuclear, building or traffic legislation:

- a) authorized inspectors consulted by the licensing or supervisory authority in accordance with Sec. 20 of the Atomic Energy Act,
- b) authorized inspectors from the institution competent under the building code of the respective State or the inspecting engineers put in charge by this institution,
- c) authorized inspectors from the institution competent under the traffic legislation or the authorized inspector consulted by this agency.

3 General provisions

Load attaching points shall at least comply with the generally accepted engineering standards.

4 Special provisions

4.1 Classification

The classification of the load attaching points with respect to the additional or increased requirements shall be specified within the framework of the nuclear licensing and supervisory procedure. Examples for the classification are presented in Annex D.

4.2 Load attaching points with additional requirements

If, in the course of transportation of nuclear fuel, other radioactive substances, radioactive plant components or other loads, a failure of the load attaching point is expected to lead

- a) to the immediate danger of a release of radioactivity with a subsequent radioactive exposure in the plant
or
- b) to a loss of reactor coolant which cannot be isolated, or to a detrimental effect on, and going beyond the redundancy of, the safety equipment which is necessary to shut down the reactor at any time, to maintain the reactor in the shut-down condition or to remove residual heat,

then the additional requirements specified in this safety standard that exceed the requirements under Section 3 shall apply to these load attaching points.

4.3 Load attaching points with increased requirements

If, in the course of transportation of nuclear fuel, other radioactive substances, radioactive components or other loads, a failure of the lifting equipment is expected to lead

- a) to a criticality accident
or
- b) to the danger of a release of radioactivity with a subsequent radioactive exposure in the environment of the nuclear power plant

then more stringent requirements specified in this safety standard that exceed the requirements under Section 3 shall apply to these load attaching points.

4.4 Load attaching points on core components

Load attaching points on core components according to clause 1 (2) shall, in addition to the general provisions of Section 3, meet the requirements of the pertinent Sections of this safety standard.

5 Analytical and structural design

5.1 General

5.1.1 Load distribution

(1) In the case of statically indeterminate systems where the calculated load distribution over all load attaching points is not ensured by the load suspension device, the maximum possible load, however, at least one half of the total load, shall be proved for each load attaching point.

(2) Where additional forces, e.g. as a result of breaking loose, static friction or tilting, cannot be precluded by design measures, these forces shall be taken into account.

(3) For load attaching points no verification of adequate protection against external impacts is required.

(4) Ambient conditions such as pressure, temperature, fluid and radiation exposure shall be considered in the design.

(5) Component-specific requirements for the analytical and structural design, calculation, materials, tests and inspections, operation and maintenance shall be considered.

(6) For load attaching points used as support and attachment on the transportation means during transportation outside the nuclear power plant, the loadings resulting from transports inside and outside the nuclear power plant shall be considered in the analysis for cyclic operation.

5.1.2 Stress analysis

A general stress analysis is required for all load attaching points with a stress cycle number N_{σ} equal to or less than $2 \cdot 10^4$; additionally, an analysis for cyclic operation is required for load attaching points where the number of stress cycles N_{σ} exceeds $2 \cdot 10^4$.

5.1.3 Determination of the number of stress cycles

(1) The number of stress cycles shall be calculated in accordance with the following equation

$$N_{\sigma} = U \cdot Z_{Sch} \cdot k_a \quad (5.1-1)$$

using $k_a = 10$

$Z_{Sch} = 10$ for controlled drives and cable drives
with creep speed

$Z_{Sch} = 20$ for other drives

Where

k_a number of stress cycles as a result of a switching operation

N_{σ} number of (dynamic) stress cycles

U number of operational load cycles; an operational load cycle is the process between taking up and setting down of the load

Z_{Sch} number of switching operations per operational load cycle (switching on to accelerate corresponds to one switching operation; switching over to braking, likewise).

(2) The cyclic history for the strength analysis shall be converted by the elementary Miner's Rule (linear damage accu-

mulation at continuous stress number diagram in a double logarithmic representation in accordance with **Annex E**) to a damage-equivalent single-step load collective. The stress amplitude belonging to N_{σ} shall be determined under consideration of the load coefficient (live load factor) specified in the following Sections for the individual components, whereby, as the most conservative case, the maximum stress amplitude after connection of the load shall be assumed as remaining constant over the entire operational load cycle.

(3) If the actual stresses within a load cycle are known from experimental investigations or from appropriate estimation of the cyclic stressing history with suitable analytical models (e.g. taking account of the vibration energy consumed by the work loss being impressed on the system by the coupling impact), the analysis for cyclic operation may be performed on this basis.

5.1.4 Structural design

5.1.4.1 Load attaching points in acc. with clause 1 (1)

(1) DIN 18 800-1 shall apply to the construction of structural steel components and weld seams where the number of stress cycles is equal to or less than $2 \cdot 10^4$ and DIN 15 018-1 and DIN 15 018-2 to structural steel components and weld seams where the number of stress cycles exceeds $2 \cdot 10^4$.

(2) The requirements in accordance with VDI 2230 Sheet 1 apply to the construction of bolted connections.

(3) Only those load attaching points are permissible which are either an integral part of the load, are bolted on or welded on and, in the case of concrete parts, are anchored in the concrete.

(4) The load attaching point shall be designed such that it can only be positively attached to the lifting equipment. Safeguards shall be provided to prevent any inadvertent release of the load suspension device from the load attaching point.

(5) When employing rope slings in accordance with DIN 3088 and chain slings in accordance with DIN 5688-3 with load suspension devices and load attachment rigging, only 50 % of the load capacity specified in these standards shall be used. This shall be taken into account in the structural design of load attaching points.

(6) The surfaces of load attaching points shall be such that they can be easily decontaminated.

5.1.4.2 Load attaching points in acc. with clause 1 (2)

(1) The load attaching point shall be designed such that it can only be positively attached to the lifting equipment. Safeguards shall be provided to prevent any inadvertent release of the load suspension device from the load attaching point.

(2) For welded joints the provisions of the drawings and related specifications apply.

(3) The requirements in accordance with VDI 2230 Sheet 1 apply to the construction of bolted connections.

5.2 Structural steel components

5.2.1 Additional requirements

5.2.1.1 Live load factor

(1) The dead weight of the load shall be multiplied by a live load factor of $\psi = 1.35$ for determination of the design loads.

(2) Where a smaller live load factor than that resulting from (1) is used, it shall be proved for each individual case; in addition, this value shall be multiplied by a factor of 1.12 before using it in further calculations.

5.2.1.2 General stress analysis

The general stress analysis shall be carried out in accordance with DIN 18 800-1 for the "main forces" load case, H.

5.2.1.3 Analysis for cyclic operation

(1) In accordance with DIN 15 018-1, the loading level group B 3 shall be used in the analysis of the cyclic operation of structural steel components.

(2) The allowable stresses for the analysis of cyclic operation shall be in accordance with **Annex F** when using austenitic materials approved under the building code.

5.2.2 Increased requirements

5.2.2.1 Live load factor

(1) The dead weight of the load shall be multiplied by a live load factor of $\psi = 1.8$ for determination of the design loads.

(2) Where a smaller live load factor than that resulting from (1) is used, it shall be proved for each individual case; in addition, this value shall be multiplied by a factor of 1.25 before using it in further calculations.

(3) The loads resulting from shifting of the load due to a failure of a component of the lifting equipment in accordance with Sec. B 2.1.2 KTA 3902 shall be taken into account if more unfavourable stresses result than those determined with the live load factors specified above. It is permissible to use 1.1 times the stresses of the "main and additional forces" load case, HZ, in accordance with DIN 15 018-1 or DIN 18 800-1 for this load case.

5.2.2.2 General stress analysis

The general stress analysis shall be carried out in accordance with DIN 18 800-1 for the "main forces" load case, H.

5.2.2.3 Analysis for cyclic operation

(1) In accordance with DIN 15 018-1 the loading level group B 4 shall be used in the analysis for cyclic operation of structural steel components.

(2) The allowable stresses for the analysis of cyclic operation shall be in accordance with **Annex F** when using austenitic materials approved under the building code.

5.3 Lifting lugs, bolts, tie rods and similar components

5.3.1 Additional requirements

5.3.1.1 Live load factor

(1) The dead weight of the load shall be multiplied by a live load factor of $\psi = 1.35$ for determination of the design loads.

(2) Where a smaller live load factor than that resulting from (1) is used, it shall be proved for each individual case; in addition, this value shall be multiplied by a factor of 1.12 before using it in further calculations.

5.3.1.2 General stress analysis

(1) The following safety factors shall be proved for the components

$$v_{\sigma} = \frac{R_{eH} \text{ or } R_{p0.2}}{\sigma} \geq 1.5 \quad (5.3-1)$$

$$v_{\tau} = \frac{\tau_{st}}{\tau} \geq 1.5 \quad (5.3-2)$$

$$v_{\sigma_v} = \frac{R_{eH} \text{ or } R_{p0.2}}{\sigma_v} \geq 1.5 \quad (5.3-3)$$

$$\sigma_v = \sqrt{\sigma^2 + 3 \cdot \tau^2} \quad (5.3-4)$$

where

σ normal stress from the maximum load occurring

σ_v stress intensity

R_{eH} or $R_{p0.2}$ yield point or proof stress

τ shear stress

τ_{st} yield point for torsional stress
 $< R_{eH} / \sqrt{3}$ or $R_{p0.2} / \sqrt{3}$

(2) The weld seams shall be dimensioned in accordance with DIN 18 800-1 for the "main forces" load case, H.

5.3.1.3 Analysis for cyclic operation

(1) The safety for the creep rupture stress range $2 \cdot N_Z \leq N_{\sigma} < N_D$ shall be proved as follows:

$$v_{\sigma} = \frac{\bar{\sigma}_D}{\sigma} \geq 2.0 \quad (5.3-5)$$

$$v_{\tau} = \frac{\bar{\tau}_D}{\tau} \geq 2.0 \quad (5.3-6)$$

and

$$\left(\frac{\sigma}{\bar{\sigma}_D} \right)^2 + \left(\frac{\tau}{\bar{\tau}_D} \right)^2 \leq \left(\frac{1.0}{2.0} \right)^2 \quad (5.3-7)$$

(2) The safety for the endurance strength range $N_{\sigma} \geq N_D$ shall be proved as follows:

$$v_{\sigma} = \frac{\sigma_D}{\sigma} \geq 2.0 \quad (5.3-8)$$

$$v_{\tau} = \frac{\tau_D}{\tau} \geq 2.0 \quad (5.3-9)$$

and

$$\left(\frac{\sigma}{\sigma_D} \right)^2 + \left(\frac{\tau}{\tau_D} \right)^2 \leq \left(\frac{1.0}{2.0} \right)^2 \quad (5.3-10)$$

where

$\sigma_D = f(\sigma_n, K_n)$ endurance strength for normal stresses

σ_n endurance strength of the material test specimen for normal stresses at a 50 % survival probability

K_n product of endurance strength reduction factor, roughness factor and shape factor for normal stresses

N_D $5 \cdot 10^6$ stress cycles

N_Z 10^4 stress cycles

N_{σ} number of actual stress cycles

R_m tensile strength

$\bar{\sigma}_D$ creep rupture stress for normal stresses

$\tau_D = f(\tau_t, \tau_{K_t})$ endurance strength for torsional stresses

τ_t endurance strength of the material test specimen for torsional stresses at a 50 % survival probability

$\bar{\tau}_D$ creep rupture stress for shear stresses

τ_{K_t} product of endurance strength reduction factor, roughness factor and shape factor for torsional stresses

(3) The S/N diagrams are shown in **Annex E**. The allowable stresses for the analysis of cyclic operation shall be in accordance with **Annex F**, insofar as applicable, when using austenitic materials approved under the building code.

(4) Material characteristics, endurance strength reduction factor, roughness factor, stress concentration factor and shape factor shall be taken from the relevant literature, e.g. [1] to [6] (see **Annex G**).

(5) If materials not dealt with in the literature in **Annex G** are used, the above-mentioned characteristic values shall be verified and guaranteed in each individual case.

(6) In accordance with DIN 15 018-1 the loading level group B 6 shall be used when dimensioning the weld seams.

5.3.2 Increased requirements

5.3.2.1 Live load factor

(1) The dead weight of the load shall be multiplied by a live load factor of $\psi = 1.8$ for determination of the design loads.

(2) Where a smaller live load factor than that resulting from (1) is used, it shall be proved for each individual case; in addition, this value shall be multiplied by a factor of 1.25 before using it in further calculations.

(3) The loads resulting from shifting of the load due to a failure of a component of the lifting equipment in accordance with Sec. B 2.1.2 KTA 3902 shall be taken into account if more unfavourable stresses result than those determined with live load factors specified above. A general stress analysis shall be performed for this load case, where a safety factor equal to or greater than 1.25 against the yield point shall be taken into account. In the case of weld seams it is permissible to use 1.1 times the stresses of the "main and additional forces" load case, HZ, in accordance with DIN 18 800-1.

5.3.2.2 General stress analysis

(1) The safety factors in accordance with Section 5.3.1.2 shall be proved for the components.

(2) Weld seams shall be dimensioned in accordance with DIN 18 800-1 for the "main forces" load case, H.

5.3.2.3 Analysis for cyclic operation

(1) The safety for the creep rupture stress range $2 \bullet N_Z \leq N_\sigma < N_D$ shall be proved as follows:

$$v_\sigma = \frac{\bar{\sigma}_D}{\sigma} \geq 2.5 \quad (5.3-11)$$

$$v_\tau = \frac{\bar{\tau}_D}{\tau} \geq 2.5 \quad (5.3-12)$$

and

$$\left(\frac{\sigma}{\bar{\sigma}_D}\right)^2 + \left(\frac{\tau}{\bar{\tau}_D}\right)^2 \leq \left(\frac{1.0}{2.5}\right)^2 \quad (5.3-13)$$

(2) The safety for the endurance strength range $N_\sigma \geq N_D$ shall be proved as follows:

$$v_\sigma = \frac{\sigma_D}{\sigma} \geq 2.5 \quad (5.3-14)$$

$$v_\tau = \frac{\tau_D}{\tau} \geq 2.5 \quad (5.3-15)$$

and

$$\left(\frac{\sigma}{\sigma_D}\right)^2 + \left(\frac{\tau}{\tau_D}\right)^2 \leq \left(\frac{1.0}{2.5}\right)^2 \quad (5.3-16)$$

(3) The S/N diagrams are shown in **Annex E**. The allowable stresses for the analysis of cyclic operation shall be in accordance with **Annex F**, insofar as applicable, when using austenitic materials approved under the building code.

(4) Material characteristics, endurance strength reduction factor, roughness factor, stress concentration factor and shape factor shall be taken from relevant literature, e.g. [1] to [6] (see **Annex G**).

(5) If materials not dealt with in the literature in **Annex G** are used, the above-mentioned characteristic values shall be verified and guaranteed in each individual case.

(6) In accordance with DIN 15 018-1 the loading level group B 6 shall be used in dimensioning the weld seams.

5.4 Bolted connections

5.4.1 Additional requirements

5.4.1.1 Live load factor

(1) The dead weight of the load shall be multiplied by a live load factor of $\psi = 1.35$ for determination of the design loads.

(2) Where a smaller live load factor than that resulting from (1) is used, it shall be proved for each individual case; in addition, this value shall be multiplied by a factor of 1.12 before using it in further calculations.

5.4.1.2 General stress analysis

(1) VDI 2230 Sheet 1 shall be used for dimensioning bolted connections. The following requirements shall be met:

- the degree of utilization of the yield stress limit when tightening shall be limited to 0.7,
- the degree of utilization of the yield stress limit as a result of operational additional bolt forces shall be limited to 0.1.

(2) If bolted connections in accordance with DIN EN 20 898-1 and DIN EN 20 898-2 or DIN EN ISO 3506-1 and DIN EN ISO 3506 subject to additional tensional loading are used, then the determined bolt load shall be increased by a factor of 1.12.

5.4.1.3 Analysis for cyclic operation

(1) The analysis for cyclic operation as endurance strength analysis shall be performed in accordance with VDI 2230 Sheet 1. A safety factor of at least 2.0 shall be observed with regard to the endurance strength of the thread.

(2) A creep rupture stress analysis shall be performed in accordance with 5.3.1.3 for bolted connections; the position of the fatigue curve in the creep rupture stress range shall be verified. A safety factor of at least 2.0 shall be verified with regard to failure due to fatigue.

5.4.2 Increased requirements

5.4.2.1 Live load factor

(1) The dead weight of the load shall be multiplied by a live load factor of $\psi = 1.8$ for determination of the design loads.

(2) Where a smaller live load factor than that resulting from (1) is used, it shall be proved for each individual case; in addition, this value shall be multiplied by a factor of 1.25 before using it in further calculations.

(3) The loads resulting from shifting of the load due to a failure of a component of the lifting equipment in accordance with Sec. B 2.1.2 KTA 3902 shall be taken into account if more unfavourable stresses result than those determined with

live load factors specified above. The degree of utilization of the yield stress limit shall be limited to 0.3 for this load case.

5.4.2.2 General stress analysis

(1) VDI 2230 Sheet 1 together with the conditions specified in 5.4.1.2 shall apply to the dimensioning of bolted connections.

(2) If bolted connections in accordance with DIN EN 20 898-1 and DIN EN 20 898-2 or DIN EN ISO 3506-1 and DIN EN ISO 3506 subject to additional tensional loading are used, then the required number of bolts shall be doubled or the determined bolt load shall be increased by a factor of 1.5. These requirements are not imposed, if bolts in accordance with Materials Test Sheet WPB 14 to **Annex A** are used.

5.4.2.3 Analysis for cyclic operation

(1) The analysis for cyclic operation as endurance strength analysis shall be performed in accordance with VDI 2230 Sheet 1. A safety factor of at least 2.5 shall be verified with regard to failure due to fatigue of the thread.

(2) A creep rupture stress analysis shall be performed in accordance with 5.3.1.3 for bolted connections; the position of the fatigue curve in the creep rupture stress range shall be verified. A safety factor of at least 2.5 shall be verified with regard to failure due to fatigue.

5.5 Application of loads into structural concrete components

5.5.1 Additional requirements

5.5.1.1 Live load factor

(1) The dead weight of the load shall be multiplied by a live load factor of $\psi = 1.35$ for determination of the design loads.

(2) Where a smaller live load factor than that resulting from (1) is used, it shall be proved for each individual case; in addition, this value shall be multiplied by a factor of 1.12 before using it in further calculations.

5.5.1.2 Application of load

(1) The proof of load application into a structural concrete component shall be performed in accordance with the requirements specified particularly in DIN 1045, DIN 4212 and in the guidelines for dimensioning and construction of steel composite girders.

(2) DIN 1055-1 and DIN 1055-3 shall apply to the determination of design loads.

(3) The additional load on the structural concrete component resulting from the load test specified in No. 3 d) **Table 9-1** shall individually be taken into account corresponding to the application of the load.

5.5.2 Increased requirements

5.5.2.1 Live load factor

(1) The dead weight of the load shall be multiplied by a live load factor of $\psi = 1.8$ for determination of the design loads.

(2) Where a smaller live load factor than that resulting from (1) is used, it shall be proved for each individual case; in addition, this value shall be multiplied by a factor of 1.25 before using it in further calculations.

The loads resulting from shifting of the load due to a failure of a component of the lifting equipment in accordance with Sec. B 2.1.2 KTA 3902 shall be taken into account if more

unfavourable stresses result than those determined with the live load factors specified above.

5.5.2.2 Application of load

(1) The proof of load application into a structural concrete component shall be performed in accordance with the requirements specified particularly in DIN 1045, DIN 4212 and in the guidelines for dimensioning and construction of steel composite girders.

(2) DIN 1055-1 and DIN 1055-3 shall apply to the determination of design loads.

(3) The additional load on the structural concrete component resulting from the load test specified in No. 3 d) **Table 9-1** shall individually be taken into account corresponding to the application of the load.

5.6 Ropes and chains

Ropes and chains are not permitted as load attaching points.

5.7 Core components

5.7.1 General

For the determination of the design loads the dead weight of the load shall be multiplied by a load intensification factor $f_{\bar{U}} = 2.0$. The load intensification factor comprises the live load factor and additional forces from frictional contacts.

5.7.2 General stress analysis

(1) For the load attaching points of core components only primary stresses are considered. The following stress intensities shall be complied with:

a) allowable primary membrane stress intensity

$$P_{m,zul} = 0.66 \cdot R_{p0.2T} \quad (5.7-1)$$

b) allowable primary membrane plus bending stress intensity

$$P_{m+b,zul} = 1.0 \cdot R_{p0.2T} \quad (5.7-2)$$

with

$R_{p0.2T}$ elevated temperature proof stress

Note:

Primary stresses are stresses necessary to satisfy the laws of equilibrium of external forces and moments.

Membrane stresses are defined as the average stress value of the individual stress component over the cross-section under consideration.

Bending stresses are defined as variable linear stresses proportional to their distance from the neutral axis.

(2) The stress intensities shall be derived from the individual stress components in accordance with the theory of von-Mises.

(3) The allowable primary stress intensities for welds are derived from the allowable primary stress intensity of the base material multiplied by the weld factors v and v_2 for the type of loading and weld quality. The weld factors v shall be taken from **Table 5-1**.

For the weld factors v_2 to consider the weld quality the following values shall be used:

$$v_2 = 1.0 \quad \text{for proved weld quality} \quad (5.7-3)$$

$$v_2 = 0.5 \quad \text{without proof of weld quality} \quad (5.7-4)$$

(4) VDI 2230 Sheet 1 shall be used for dimensioning bolted connections. The following requirements shall be met:

a) the degree of utilization of the yield stress limit when tightening shall be limited to 0.7,

b) the degree of utilization of the yield stress limit as a result of operational additional bolt forces shall be limited to 0.1.

Type of weld	Type of loading	Weld factor v
Butt weld	Tension	1.0
	Compression	1.0
	Bending	1.0
	Shear	0.8
Fillet weld	Any loading	0.8

Table 5-1: Weld factors v to consider the respective type of loading

5.7.3 Experimental analysis

(1) For load attaching points of core components the limits of primary membrane plus bending stress intensity need not be complied with if, by testing on a series-produced component or prototype component, it can be proved that

a) $L_{max} \leq L_G$ (5.7-5)

and

b) $L_{max} \leq 0.44 \cdot L_U$ (5.7-6)

where

$L_{max} = f_{\ddot{U}} \cdot \text{dead weight (design load)}$

$f_{\ddot{U}} = 2.0$ (load intensification factor)

L_G service load (deformations are limited such that detaching or attaching of the load suspension device is still possible)

L_U rupture load or maximum test load

(2) For all experimental analyses the differences between the conditions on the test component and the most unfavourable combination of the components used (e.g. dimensional tolerances, specified minimum design strength values) shall be taken into account. The load applied during the test shall reflect the true conditions on the component. The consideration of these requirements shall ensure that the loads determined during the test reflect the conservative load carrying capacity of the true structure at specified loads.

5.7.4 Analysis for cyclic operation

For load attaching points on core components the number of stress cycles N_G is less than $2 \cdot 10^4$. Therefore, no analysis for cyclic operation need be made.

6 Materials

6.1 Selection of Materials

The selection of materials shall be based, in addition to the strength characteristics (yield point, tensile strength) governing the dimensioning, also on the toughness characteristics (resistance to brittle fracture) and, if necessary, on the suitability for welding, the loading capacity in thickness direction and where required the corrosion resistance. In the case of bolted connections a suitable combination of materials shall be used.

6.1.1 Materials in accordance with Annex A

(1) Materials tests are represented in the form of materials test sheets in **Annex A** for the usually employed materials; the materials shall be within the dimensional range as specified in the quality standards.

(2) The mechanical properties in accordance with SEW 011 shall be used in the case of product forms made of materials in accordance with DIN 17 100 which are, however, outside the dimensional range specified in DIN 17 100.

6.1.2 Other materials

(1) Other materials and dimensional limits than those specified in the materials test sheets under **Annex A** are only permitted if corresponding materials test sheets have been compiled and have been subjected to design approval.

(2) Where materials are used for which no allowable stresses are specified in the generally valid engineering standards, the allowable stresses for the general stress analysis and analysis for cyclic operation shall be derived by theoretical analysis or from realistic experiments.

6.2 Testing of materials

(1) The tests specified in the materials test sheets under **Annex A** shall be conducted and certified in accordance with their classification.

(2) The test results shall meet the specified requirements.

6.3 Materials identification marking

(1) The materials identification marking of the product forms shall be maintained during processing.

(2) The transfer of markings on product forms for further processing shall, in the case of a classification in accordance with Section 4.2, be checked by the plant authorized inspector in accordance with DIN EN 10 204 and, in the case of a classification in accordance with Section 4.3, by the authorized inspector under Sec. 20 Atomic Energy Act or, insofar as necessary, by the authorized inspector.

7 Design approval

7.1 Required documents

The documents specified below shall be submitted in clear and checkable form for design approval by the authorized inspector.

Note:

In the case of components to be tested under building legislation, the design approval in accordance with this safety standard is conducted as a static test.

In the case of components subject to approval under traffic legislation, the design approval in accordance with this safety standard is carried out within the framework of type testing under traffic legislation.

7.1.1 Load attaching points in acc. with clause 1 (1)

7.1.1.1 Design data sheet

The design data sheet shall contain the following data:

- a) classification of the load attaching point,
- b) dead weight of the load and specifications regarding the centre of gravity, point of load application and direction of forces as well as temperatures, fluids and radiological exposure which may impair the material characteristics,

- c) loads resulting from shifting of the load due to a failure of a component of the lifting equipment in accordance with Sec. B 2.1.2 KTA 3902 in the case of increased requirements.

7.1.1.2 General arrangement drawings, detailed drawings and parts lists with material data

The general arrangement drawings, detailed drawings and parts lists with material data shall contain the following data:

- location and arrangement of the load attaching points,
- description of the delimitation between load attaching point and load,
- dimensions for strength calculation,
- correlation of the individual parts to the materials test sheets,
- type of fasteners, specifications in the case of bolted joints pretensioned as specified.

7.1.1.3 Strength calculations

The strength calculations shall contain the following data:

- stress, strength and safety analyses for all components in the lines of force up to and including the connection of the load attaching point to the load,
- Indication of model structure and quotation of program description, insofar as the calculations are made using data processing systems,
- stress-strain measurement program if this is planned to supplement the calculations.

7.1.1.4 Materials test sheets

For materials not listed in **Annex A** materials test sheets with the following data shall be established:

- identification number of the materials test sheet,
- product form,
- material designation,
- test requirements for the material with indication of the extent of testing and the certification in accordance with DIN EN 10 204,
- identification marking of the material.

7.1.1.5 Welding procedure sheet

The welding procedure sheet shall contain the following data:

- type of weld seams and their assignment,
- base metals, weld filler metals and consumables,
- welding procedure and welder's certification,
- heat treatment,
- welder's qualification,
- evaluation group,
- welding data.

7.1.1.6 Qualification certificate for welding

(1) The manufacturer shall prove his qualification in accordance with DIN 18 800-7 for welding components for which a general stress analysis is required.

(2) In addition to the qualification in accordance with DIN 18 800-7, a qualification in accordance with DIN 15 018-2 is required for components for which an analysis for cyclic operation is required.

(3) Where materials and welding procedures not covered by DIN 15 018-2 and DIN 18 800-1 are used, certificates on cor-

responding welding procedure qualification tests shall be submitted. Where no specifications exist for performing welding procedure qualification tests on specific material combinations, production weld tests shall be conducted within final inspection by agreement with the authorized inspector.

7.1.1.7 Test and inspection sequence plan for final inspection

The test and inspection sequence plan shall contain the following data:

- requirements and extent of the tests and inspections in accordance with Section 8,
- test and inspection sequence as well as type of tests and inspections and certificates,
- person performing the test or inspection (manufacturer, authorized inspector).

7.1.1.8 Test and inspection sequence plan for the acceptance test

The test and inspection sequence plan shall contain the following data:

- requirements and extent of the tests and inspections in accordance with Section 9,
- test and inspection sequence.

7.1.1.9 Test and inspection sequence plan for in-service inspections

The test and inspection sequence plan shall contain the following data:

- requirements and extent of the tests and inspections in accordance with Section 10,
- intervals between tests and inspections.

7.1.2 Load attaching points in acc. with clause 1 (2)

7.1.2.1 Drawings, parts lists and specifications

The general arrangement drawings, detailed drawings, parts lists and specifications shall contain the following data:

- dimensions for strength calculation of load attaching points,
- material data to make assignment of individual parts to the materials test sheets possible,
- type of fasteners, specifications in the case of bolted joints pretensioned as specified.

7.1.2.2 Strength calculations

The strength calculations shall contain the following data:

- location and arrangement of the load attaching points,
- description of the delimitation between load attaching point and load,
- dead weight of the load and indication of the point of load application and direction of forces as well as temperatures, fluids and radiological exposure which may impair the material characteristics,
- stress, strength and safety analyses for the load attaching point,
- Indication of model structure and quotation of program description, insofar as the calculations are made using data processing systems,
- description of the test program and test results in the case of experimental analysis.

7.1.2.3 Materials test sheets

For materials not listed in **Annex A** materials test sheets with the following data shall be established:

- a) identification number of the materials test sheet,
- b) product form,
- c) material designation,
- d) test requirements for the material with indication of the extent of testing and the certification in accordance with DIN EN 10 204,
- e) identification marking of the material.

7.1.2.4 Welding procedure documentation

Where a welding procedure is applied during fabrication of the load attaching point, a document shall be established to specify the applied welding procedure qualification requirements. These requirements comprise the establishment of welding procedure sheets, the performance of welding procedure qualification and, where required, the welder's qualification in the case of manual welding.

7.1.2.5 Test and inspection documents

The tests and inspections to be performed by the manufacturer shall be fixed.

7.2 Procedure

(1) The documents submitted in accordance with Section 7.1.1 or 7.1.2 shall be checked for:

- a) completeness,
- b) correspondence of the data with the specified values and requirements,
- c) compliance with the licensing provisions and requests of the supervisory authority.

(2) The documents submitted in accordance with Sections 7.1.1.1 and 7.1.1.2 shall, additionally, be checked for:

- a) accessibility of the load attaching points for maintenance and repair work and for in-service inspections,
- b) correspondence of the data regarding materials in the parts lists and in the associated materials test sheets.

(3) The documents submitted in accordance with Sections 7.1.1.3 and 7.1.2.2 shall, additionally, be checked for:

- a) correctness and completeness of the design loads,
- b) correctness and completeness of the calculations,
- c) observance of the allowable stresses and safety factors.

(4) The materials test sheets compiled in accordance with Sections 7.1.1.4 and 7.1.2.3 shall be checked for correctness with regard to the extent of testing and type of certification.

(5) The welding procedure sheet submitted in accordance with Sections 7.1.1.5 and 7.1.2.4 shall be checked with regard to the suitability of the intended welding procedure as well as to the correctness and completeness of the data.

(6) The qualification certificate for welding submitted in accordance with Sections 7.1.1.6 and 7.1.2.4 shall be checked for correspondence with the chosen welding procedures and materials.

7.3 Certification of design approval

(1) The authorized inspector shall establish a certificate on the performance of the design approval and the results obtained.

(2) In the event of a positive result, the design approval is regarded as concluded upon submission of this certificate.

8 Final inspection

8.1 Load attaching points in acc. with clause 1 (1)

8.1.1 General

Within the final inspection the correspondence of the design approval documents with the construction of the load attaching point shall be checked.

8.1.2 Documents

The following documents shall be available:

- a) test and inspection sequence plan for the final inspection in accordance with 7.1.1.7,
- b) detailed drawings and parts lists with data on materials,
- c) materials documentation,
- d) certificate concerning the transfer of markings on product forms in accordance with Section 6.3,
- e) welding procedure sheets in accordance with 7.1.1.5,
- f) certificates on the suitability for welding in accordance with 7.1.1.6.

8.1.3 Extent of tests and inspections

The extent of the final inspection is specified in **Table 8-1**. The non-destructive tests shall be conducted in accordance with **Annex B**. The manufacturer shall perform 100 % of the tests. The tests and inspections to be performed by the authorized inspector are specified for the individual test and inspection steps in **Table 8-1**.

8.1.4 Certification of final inspection

(1) The authorized inspector shall establish a certificate on the performance of the final inspection and the results obtained.

(2) In the event of a positive result, the final inspection is regarded as concluded upon submission of this certificate.

8.2 Load attaching points in acc. with clause 1 (2)

8.2.1 General

Within the final inspection the correspondence of the design approval documents with the construction of the load attaching point shall be checked.

8.2.2 Documents

The following documents shall be available:

- a) drawings, parts lists and specifications,
- b) test and inspection documents in accordance with 7.1.2.5,
- c) materials documentation in accordance with materials test sheets,
- d) welding procedure qualifications to 7.1.2.4,

8.2.3 Extent of tests and inspections

The type and extent of the tests and inspections to be performed by the manufacturer shall be taken from the related specification. The extent of tests and inspections by the authorized inspector are specified in **Table 8-1**.

8.2.4 Certification of final inspection

(1) The type of certificate of the tests and inspections to be performed by the manufacturer shall be laid down in the specification.

(2) The authorized inspector shall establish a certificate on the performance of the final inspection and the results obtained.

(3) In the event of a positive result, the final inspection is regarded as concluded upon submission of this certificate.

9 Acceptance test

9.1 Load attaching points in acc. with clause 1 (1)

9.1.1 General

Before the load attaching point is put into service an acceptance test shall be conducted by the authorized inspector to prove that the load attaching point in its ready-for-operation condition meets the requirements with regard to load-carrying capacity and functional capability.

9.1.2 Documents

The following documents shall be available for the acceptance test:

- test and inspection sequence plan for the acceptance test in accordance with 7.1.1.8,
- documentation of the tests and inspections in accordance with Sections 7 and 8 with the associated test certificates.

9.1.3 Extent of tests and inspections

(1) The extent of the tests and inspections is shown in **Table 9-1**.

(2) Tests already conducted and documented within the framework of the final inspection may be dispensed with in the acceptance test.

9.1.4 Certification of acceptance test

(1) The authorized inspector shall establish a certificate on the performance of the acceptance test and the results obtained.

(2) In the event of a positive result, the acceptance test is regarded as concluded upon submission of this certificate.

9.2 Load attaching points in acc. with clause 1 (2)

For load attaching points on core components an acceptance test is not required.

10 In-service inspections

10.1 Load attaching points in acc. with clause 1 (1)

10.1.1 General

(1) Unless otherwise specified, the in-service inspections shall be conducted by the licensee in test intervals as specified in 10.1.3. The inspection dates shall be agreed upon in good time between the licensee and the authorized inspector.

(2) If load attaching points on loads are not used for an interval longer than that between two in-service inspections, the next in-service inspection shall, at the latest, be conducted prior to the use of these load attaching points.

(3) If the in-service inspections lead to the detection of defects on load attaching points, a new inspection to an extent related to the size of the repaired defects is required after repair. The period for repair of the defects shall be agreed upon with the authorized inspector.

10.1.2 Documents

In addition to the test and inspection sequence plan for in-service inspections the following documents shall be available:

- test instructions,
- certificate of the last in-service inspection; the acceptance test certificate shall be submitted for the first in-service inspection,
- records on all maintenance and repair work carried out,
- records on the number of transports carried out since the last in-service inspection in the case of load attaching points on loads transported inside and outside the nuclear power plant.

Note:

A transport means the entire cycle consisting of to-and-fro conveyance to or from the site of the nuclear power plant.

10.1.3 Inspection intervals

(1) The in-service inspections on load attaching points on loads which are used only inside the nuclear power plant shall essentially be conducted as visual inspections and functional tests at annual intervals. Additional in-service inspections shall be conducted every 3 years for load attaching points to Section 4.3.

(2) The in-service inspections on load attaching points on loads which are used inside and outside the nuclear power plant shall be conducted as visual inspections, functional tests, mechanical integrity tests and non-destructive tests after every 15 transports, however, at the latest after 3 years. Additional tests shall be conducted after every 60 transports, however, at the latest after 6 years.

(3) The inspection intervals are specified under **Table 10-1**. If other inspection intervals are specified for the components in KTA safety standards (e.g. KTA 3201.4: 4 years for the welds of the reactor pressure vessel), a deviation from the intervals in accordance with **Table 10-1** is permitted by agreement with the authorized inspector.

10.1.4 Extent of tests and inspections

(1) The extent of the tests and inspections is specified under **Table 10-1**. Non-destructive tests shall be conducted in accordance with **Annex B**.

(2) If non-destructive tests are not possible because of local conditions (accessibility), regulations shall be specified by agreement with the authorized inspector in each individual case.

10.1.5 Certification of in-service inspections

(1) The authorized inspector shall establish a certificate on the in-service inspections carried out.

(2) In the event of a positive result, the in-service inspection is regarded as concluded upon submission of this certificate.

10.2 Load attaching points in acc. with clause 1 (2)

For load attaching points on core components no in-service inspections are required.

11 Operation and maintenance

11.1 Load attaching points in acc. with clause 1 (1)

(1) The operating instructions shall be observed when using the load attaching points.

(2) The licensee shall take care to ensure that the tests specified in the test manual (in accordance with KTA 1202) are conducted properly and in time.

(3) The load attaching points shall be checked for obvious defects before each use. If defects impairing safety are detected, the load attaching points shall not be used before the defect has been repaired.

(4) Maintenance work shall be carried out such that safety is not impaired. Load attaching points not properly repaired shall not be used.

(5) Records containing at least the following data shall be kept on all maintenance work carried out:

- a) unambiguous designation of the load attaching point,
- b) type of maintenance work,
- c) designation of the associated documents.

(6) The records of maintenance work shall be included in the documentation and submitted to the authorized inspector during the in-service inspections in accordance with Section 10.

(7) The design approval in accordance with Section 7 may be omitted for those parts to be newly installed which are manufactured exclusively in accordance with the design approval documents of the initial construction. The materials test shall be conducted in accordance with Section 6, the final inspection in accordance with Section 8 and the acceptance test in accordance with Section 9.

In the case of replacement of bolts in the lines of force of the load attaching point (LAP) by new ones, a new load test in accordance with **Table 9-1** may be omitted, provided, less than 50 % of the bolts at the LAP are replaced.

11.2 Load attaching points in acc. with clause 1 (2)

(1) The operating instructions shall be observed when using the load attaching points.

(2) Repair shall be carried out in accordance with a qualified procedure and be documented accordingly.

12 Documentation

12.1 General

The documentation shall ensure that all monitored manufacturing processes and tests, in-service inspections and maintenance tasks in accordance with Sections 6 to 11 can be traced back.

12.2 Compilation of documents

(1) The documents shall be compiled in accordance with KTA 1404.

(2) The compiled documents shall include the design approval documents as well as all proofs, records and certifications which confirm the actual condition and the tests and inspections carried out.

12.3 Procedure of documentation

(1) Documentation of manufacturing documents shall accompany the manufacturing process. The manufacturer shall ensure that the documentation, including that of subcontractors, is complete.

(2) The licensee is responsible for the continued documentation of maintenance and in-service inspections, unless provided otherwise in individual cases.

Test / Inspection	Inspection by authorized inspector		
	Additional requirements to Section 4.2	Increased requirements to Section 4.3	Core components to Section 4.3
a) Receiving inspection of identification marks and stampings, if any, on the product forms	—	—	—
b) Material identification marks of components for compliance with parts list to Section 6.3	X	X	X
c) For tensile-loaded components (in thickness direction) an ultrasonic test for detecting laminations in weld-junction areas	25 %	25 %	—
d) Check for compliance of the location, arrangement, dimensions and assembly with design approval documents	X	X	X
e) Check of threads on load-bearing bolts and nuts with additional tensile load using thread ring gauge and thread plug gauge to DIN 13-13	—	X	
f) Observation of welding data	25 %	25 %	X
g) Visual inspection of welds	25 %	25 %	X
h) Non-destructive testing of welds specified in the final inspection test and inspection sequence plan/table:			
- Surface crack detection	25 %	25 %	X
- Ultrasonic test or radiography for butt welds: For butt welds with wall thicknesses equal to or smaller than 25 mm radiography shall preferably be used, alternatively ultrasonic testing; for wall thicknesses greater than 25 mm and equal to or smaller than 40 mm ultrasonic testing shall preferably be used, alternatively radiography. For wall thicknesses exceeding 40 mm ultrasonic testing shall be used. For all wall thicknesses of austenitic butt welds radiography shall be used, unless a clear test result can be obtained by ultrasonic testing.	25 % ¹⁾	100 % ¹⁾	— ¹⁾
i) Examination of repair welds in acc. with a design-approved repair welding procedure specification or a qualified welding procedure	X	X	X
j) Surface crack detection within the area of machined surfaces in finished condition	25 %	100 %	
k) Examination of the bolting torque of pretensioned bolted joints in accordance with DIN 18 800-7 unless specified otherwise in the design approval documents	10 %	10 %	X
l) Where ultrasonic testing is to be carried out as in-service inspection in lieu of surface crack detection, an ultrasonic test as basic inspection shall additionally be carried out on lifting lugs, bolts, tie-rods and similar components in their finished condition. The type and extent of this basic inspection shall be fixed in an inspection instruction.		X	
<p>X Inspection by authorized inspector, i.e. partial inspection to enable the inspector to confirm that the objectives of the respective inspection stage have been attained.</p> <p>— No inspection by the inspector.</p> <p>% Percentage share of inspection by the authorized inspector.</p> <p>¹⁾ Where the weld quality has to be verified.</p>			

Table 8-1: Extent of final inspection

No.	Test object	Tests and inspections	Performance
1	Bolted-on LAP	a) Identification marking	
		b) Visual inspections	
		c) Correct assembly	
		d) Loading test	1.25 times the load to be absorbed by the LAP. If the load is applied statically, a 1.5 times higher test load shall be applied
		e) Functional test with the load attachment rigging	
		f) Examination of bolting torque	DIN 18 800-7 unless specified otherwise in the design approval documents
		g) In the case of load attaching points in accordance with Section 4.3: surface crack detection (alternatively ultrasonic examination ¹⁾ on all surfaces in the lines of force (e.g. weld seams, lifting lugs, bolts, tie-rods and similar components) after the load test	in accordance with Annex B
2	Welded-on LAP and LAP as integral part of the load	a) Identification marking	
		b) Visual inspection	
		c) Correct location and arrangement	
		d) Loading test	1.25 times the load to be absorbed by the LAP. If the load is applied statically, a 1.5 times higher test load shall be applied
		e) Functional test with the load attachment rigging	
	f) In the case of load attaching points in accordance with Section 4.3: surface crack detection (alternatively ultrasonic examination ¹⁾ on all surfaces in the lines of force (e.g. weld seams, lifting lugs, bolts, tie-rods and similar components) after the load test	in accordance with Annex B	
3	LAP anchored in the concrete structural part	a) Identification marking	
		b) Visual inspection	
		c) Correct location and arrangement	
		d) Loading test ²⁾	1.25 times the load to be absorbed by the LAP. If the load is applied statically, a 1.5 times higher test load shall be applied
		e) Functional test with the load attachment rigging	
		f) Check on the concrete surface in the load application areas for inadmissible crack formation	
		g) In the case of load attaching points in accordance with Section 4.3: surface crack examination (alternatively ultrasonic examination ¹⁾ on all surfaces in the lines of force which remain accessible after concreting (e.g. weld seams, lifting lugs, bolts, tie-rods and similar components) after the load test	in accordance with Annex B
<p>¹⁾ See Table 8-1 I)</p> <p>²⁾ Taking clauses 5.5.1.2 (3) and 5.5.2.2 (3) into account</p>			

Table 9-1: Extent of acceptance testing

No.	Test object	Tests and inspections	Intervals between inspections			
			LAP used only inside the nuclear power plant		LAP used inside and outside the nuclear power plant	
			Section 4.2	Section 4.3	Section 4.2	Section 4.3
1	Bolted-on LAP	a) Condition, cracks, deformations, wear, corrosion	1 year	1 year	15 transports, at the latest after 3 years	15 transports, at the latest after 3 years
		b) Smooth engagement of movable parts	1 year	1 year	15 transports, at the latest after 3 years	15 transports, at the latest after 3 years
		c) Bolting torque of bolted joints in accordance with DIN 18 800-7 unless specified otherwise in the design approval documents	1 year	1 year	15 transports, at the latest after 3 years	15 transports, at the latest after 3 years
		d) Check of threads on load-bearing bolts and nuts with additional tensile load using thread ring gauge and thread plug gauge to DIN 13-13 (random)	—	3 years	—	15 transports, at the latest after 3 years
		e) Surface crack detection (alternatively ultrasonic examination ²⁾) on all surfaces in the lines of force (e.g. weld seams, lifting lugs, bolts, tie-rods and similar components)	—	3 years	—	15 transports, at the latest after 3 years
		f) Condition, cracks, deformations, wear, corrosion after dismantling the LAP ¹⁾	—	—	—	60 transports, at the latest after 6 years
		g) Load test ¹⁾ in the assembled condition (see Table 9-1 No. 1d)	—	—	—	60 transports, at the latest after 6 years
		h) Surface crack detection ¹⁾ (alternatively ultrasonic examination ²⁾) on all surfaces in the lines of force (e.g. weld seams, lifting lugs, bolts, tie-rods and similar components) after the load test	—	—	—	60 transports, at the latest after 6 years
2	Welded-on LAP and LAP as integral part of the load	a) Condition, cracks, deformations, wear, corrosion	1 year	1 year	15 transports, at the latest after 3 years	15 transports, at the latest after 3 years
		b) Smooth engagement of movable parts	1 year	1 year	15 transports, at the latest after 3 years	15 transports, at the latest after 3 years
		c) Surface crack detection (alternatively ultrasonic examination ²⁾) on all surfaces in the lines of force (e.g. weld seams, lifting lugs, bolts, tie-rods and similar components)	—	3 years	—	15 transports, at the latest after 3 years
3	LAP anchored in the concrete structural part	a) Condition, cracks, deformations, wear, corrosion	1 year	1 year	15 transports, at the latest after 3 years	15 transports, at the latest after 3 years
		b) Inadmissible crack formation on the concrete surface in the load application area	1 year	1 year	15 transports, at the latest after 3 years	15 transports, at the latest after 3 years
		c) Smooth engagement of movable parts	1 year	1 year	15 transports, at the latest after 3 years	15 transports, at the latest after 3 years
		d) Surface crack detection (alternatively ultrasonic examination ²⁾) on all surfaces in the lines of force which remain accessible after concreting (e.g. weld seams, lifting lugs, bolts, tie-rods and similar components)	—	3 years	—	15 transports, at the latest after 3 years

1) Only on load attaching points of components also subject to traffic legislation

2) See Table 8-1 I)

Table 10-1: Extent and test intervals of in-service inspections

Annex A

Materials test sheets (WPB)

WPB	Load attaching points
1	Plates and sheets, strips, wide flats and steel sections of structural carbon steel to DIN EN 10 025
2	Bars made of structural carbon steels to DIN EN 10 025
3	Forged bars and open-die forgings made of general structural steels to DIN 17 100
4	Welded tubes made of carbon steels to DIN 1626
5	Seamless tubes made of carbon steels to DIN 1629
6	Seamless or welded hollow sections of structural carbon steels to DIN EN 10 210-1
7	Bars and forgings made of quenched and tempered steels to DIN EN 10 083-1 or SEW 550
8	Plates, sheets and strips made of austenitic steels to DIN 17 440
9	Bars and forgings made of austenitic steels to DIN 17 440
10	Seamless tubes made of austenitic steels to DIN 17 458
11	Austenitic cast steel to DIN 17 445
12	Bolts and nuts to DIN EN 20 898-1, DIN EN 20 898-2 and DIN ISO 3269
13	Bolts and nuts made of austenitic steels to DIN EN ISO 3506-1, DIN EN ISO 3506-2 and DIN ISO 3269
14	Bolts and studs, thread rolled, head bolts with forged-on head, and subsequently heat-treated
15	Welded tubes made of austenitic steels to DIN 17 457
16	Bars and forgings made of stainless martensitic and austenitic-ferritic steels to DIN 17 440 or SEW 400
17	Plates, sheets and strips made of zirconium alloys
18	Forged bars and open-die forgings made of weldable fine grain structural steel to DIN 17 103

Materials test sheet 1: Plates and sheets, strips, wide flats and steel sections of structural carbon steel to DIN EN 10 025

MATERIALS TEST SHEET		WPB 1
Load attaching points		
Product form: Plates and sheets, strips, wide flats and steel sections		
Materials: S235J0 ¹⁾ (1.0114), S235J2G3 (1.0116), S235J2G4 (1.0117), S355J2G3 (1.0570), S355J2G4 (1.0577), S355K2G3 (1.0595), S355K2G4 (1.0596)		
Requirements: DIN EN 10 025 ²⁾ , DIN EN 10 164		
Tests and inspections	Certificate to DIN EN 10 204 for	
	additional requirements to Section 4.2	increased requirements to Section 4.3
1. Chemical composition: Ladle analysis	2.2	3.1.B
2. Heat treatment condition	2.2	2.2
3. Tensile test at room temperature:		
3.1 One specimen per melt and test unit	3.1.B	3.1.C
3.2 Three tensile specimens in thickness direction for product thicknesses > 20 mm and tensile loading in thickness direction: Test unit to DIN EN 10 164 Quality grade Z 25 to DIN EN 10 164	3.1.B	3.1.C
4. Notched bar impact test at test temperature to DIN EN 10 025: One set of impact test specimen per tensile test specimen as per no. 3.1 as far as the nominal dimension is ≥ 6 mm	3.1.B	3.1.C
5. Visual inspection and dimensional check: Each component	3.1.B	3.1.C
Material identification: Manufacturer's mark, steel grade, melt number, specimen number, inspector's mark, Z 25 (if demonstrated)		
¹⁾ The material S235J0 shall not be used if loaded in thickness direction. ²⁾ Repair welding is not permitted.		

Materials test sheet 2: Bars made of structural carbon steels to DIN EN 10 025

MATERIALS TEST SHEET		WPB 2
Load attaching points		
Product form:	Hot-rolled bars	
Materials:	S235J0 (1.0114), S235J2G3 (1.0116), S235J2G4 (1.0117), S355J2G3 (1.0570), S355J2G4 (1.0577), S355K2G3 (1.0595), S355K2G4 (1.0596)	
Requirements:	DIN EN 10 025 ¹⁾	
Tests and inspections	Certificate to DIN EN 10 204 for	
	additional requirements to Section 4.2	increased requirements to Section 4.3
1. Chemical composition: Ladle analysis	2.2	3.1.B
2. Heat treatment condition	2.2	2.2
3. Tensile test at room temperature: One specimen per melt and test unit	3.1.B	3.1.C
4. Notched bar impact test at test temperature and nominal dimensions to DIN EN 10 025: One set of impact test specimens per tensile test specimen	3.1.B	3.1.C
5. Visual inspection and dimensional check: Each component	3.1.B	3.1.C
6. Ultrasonic testing: For bar steel with product thicknesses ≥ 30 mm each component subject to 100 % in acc. with Annex B	3.1.B	3.1.C
Material identification: Manufacturer's mark, steel grade, melt number, specimen number, inspector's mark		
¹⁾ Repair welding is not permitted.		

Materials test sheet 3: Forged bars and open-die forgings made of general structural steels to DIN 17 100

MATERIALS TEST SHEET		WPB 3
Load attaching points		
Product form: Forged bars and open-die forgings		
Materials: RSt 37-2 (1.0038), St 37-3 (1.00116), St 52-3 (1.0570)		
Requirements: DIN EN 17 100, SEW 011		
Tests and inspections	Certificate to DIN EN 10 204 for	
	additional requirements to Section 4.2	increased requirements to Section 4.3
1. Chemical composition: Ladle analysis	2.2	3.1.B
2. Heat treatment condition	2.2	2.2
3. Tensile test at room temperature: One specimen per melt and test unit	3.1.B	3.1.C
4. Notched bar impact test at test temperature to DIN 17 100: One set of impact test specimens per tensile test specimen, as far as the nominal dimension is ≥ 15 mm	3.1.B	3.1.C
5. Visual inspection and dimensional check: Each component	3.1.B	3.1.C
6. Ultrasonic testing: For bar steel with product thicknesses ≥ 30 mm and forgings ≥ 300 kg each component subject to 100 % in acc. with Annex B	3.1.B	3.1.C
Material identification: Manufacturer's mark, steel grade, melt number, specimen number, inspector's mark		

Materials test sheet 4: Welded tubes made of carbon steels to DIN 1626

MATERIALS TEST SHEET		WPB 4
Load attaching points		
Product form:	Welded tubes	
Materials:	St 37.0 (1.0254), St 44.0 (1.0256), St 52.0 (1.0421)	
Requirements:	DIN 1626, SEP 1916 (test category B), SEP 1917 (test category B)	
Tests and inspections	Certificate to DIN EN 10 204 for additional requirements to Section 4.2	
1. Chemical composition: Ladle analysis	2.2	
2. Heat treatment condition	2.2	
3. Tensile test at room temperature: Lot size and extent of testing in acc. with DIN 1626, no. 5.3.2 and Table 7, no. 1	3.1.B	
4. Ring tests on pressure-welded tubes: Same lot size as for tensile test, extent of testing in acc. with DIN 1626 Table 7 Test to be performed acc. to DIN 1626, no. 5.4.2 or 5.4.3 at the manufacturer's discretion	3.1.B	
5. Bend test on fusion-welded tubes: Same lot size as for tensile test, extent of testing in acc. with DIN 1626 Table 7	3.1.B	
6. Non-destructive testing of welds: For pressure-welded tubes in acc. with SEP 1917 (test category B), For fusion-welded tubes in acc. with SEP 1916 (test category B)	3.1.B	
7. Visual inspection and dimensional check: Each tube	3.1.B	
Material identification: Manufacturer's mark, steel grade, inspector's mark, W for weldments		

Materials test sheet 5: Seamless tubes made of carbon steels to DIN 1629

MATERIALS TEST SHEET		WPB 5
Load attaching points		
Product form: Seamless tubes		
Materials: St 37.0 (1.0254), St 44.0 (1.0256), St 52.0 (1.0421)		
Requirements: DIN 1629		
Tests and inspections	Certificate to DIN EN 10 204 for additional requirements to Section 4.2	
1. Chemical composition: Ladle analysis	2.2	
2. Heat treatment condition	2.2	
3. Tensile test at room temperature: Lot size and extent of testing in acc. with DIN 1629, no. 5.3.2. and Table 8, no. 1	3.1.B	
4. Ring test Lot size in acc. with DIN 1629, no. 5.3.2; test to be performed in dependence of diameter and wall thickness of the tubes to DIN 1629, Table 8 and 9	3.1.B	
5. Visual inspection and dimensional check: Each tube	3.1.B	
Material identification: Manufacturer's mark, steel grade, inspector's mark, S for seamless construction		

Materials test sheet 6: Seamless or welded hollow sections of structural carbon steels to DIN EN 10 210-1

MATERIALS TEST SHEET		WPB 6
Load attaching points		
Product form:	Hot formed hollow sections (seamless or welded)	
Materials:	S275J0H (1.0149), S275J2H (1.0138), S355J0H (1.0547), S355J2H (1.0576)	
Requirements:	DIN EN 10 210-1 ¹⁾	
Tests and inspections	Certificate to DIN EN 10 204 for	
	additional requirements to Section 4.2	increased requirements to Section 4.3
1. Chemical composition: Ladle analysis	2.2	3.1.B
2. Heat treatment condition	2.2	2.2
3. Tensile test at room temperature: One specimen per melt, test unit and nominal dimension each	3.1.B	3.1.C
4. Notched bar impact test at test temperature to DIN EN 10 210-1: One set of impact test specimens per tensile test specimen, as far as the nominal dimension is ≥ 6 mm	3.1.B	3.1.C
5. Visual inspection and dimensional check: Each component	3.1.B	3.1.C
6. Non-destructive testing of weld: Each component over its full length	3.1.B	3.1.C
Material identification: Manufacturer's mark, steel grade, melt number, specimen number, inspector's mark		
¹⁾ Repair welding is not permitted.		

Materials test sheet 7: Bars and forgings made of quenched and tempered steels to DIN EN 10 083-1 or SEW 550

MATERIALS TEST SHEET		WPB 7
Load attaching points		
Product form: Bars and forgings		
Materials: Quenched and tempered steels to DIN EN 10 083-1 or SEW 550		
Requirements: DIN EN 10 083-1 ¹⁾ , SEW 550		
Tests and inspections The performance of the following tests and inspections shall be verified for the quenched and tempered condition	Certificate to DIN EN 10 204 for	
	additional requirements to Section 4.2	increased requirements to Section 4.3
1. Chemical composition: Ladle analysis	2.2	3.1.B
2. Heat treatment condition	3.1.B	3.1.B
3. Hardness test for verification of uniform heat treatment: On one end of each component three measuring points each	3.1.B	3.1.B
4. Tensile test at room temperature: One specimen per melt, dimensional range and heat treatment batch each	3.1.B	3.1.C
5. Notched bar impact test at room temperature: One set of impact test specimens per tensile test specimen, as far as the nominal dimension is ≥ 15 mm	3.1.B	3.1.C
6. Visual inspection and dimensional check: Each component	3.1.B	3.1.C
7. Materials identification check for alloyed steels: Each component, e.g. by spectroscopy	3.1.B	3.1.B
8. Ultrasonic testing: For bar steel with product thicknesses ≥ 30 mm and forgings ≥ 300 kg each component subject to 100 % in acc. with Annex B	3.1.B	3.1.C
Material identification: Manufacturer's mark, steel grade, melt number, specimen number, inspector's mark		
1) Repair welding is not permitted.		

Materials test sheet 8: Plates, sheets and strips made of austenitic steels to DIN 17 440

MATERIALS TEST SHEET		WPB 8		
Load attaching points				
Product form: Plates, sheets and strips				
Materials: Austenitic steels to DIN 17 440				
Requirements: DIN 17 440				
Tests and inspections	Certificate to DIN EN 10 204 for			
	additional requirements to Section 4.2	increased requirements to Section 4.3	core components to Section 4.4	
1. Chemical composition: Ladle analysis	2.2	3.1.B	3.1.B	
2. Heat treatment condition	2.2	2.2	2.2	
3. Check for intergranular corrosion resistance ¹⁾ : One specimen per melt and heat treatment batch each	3.1.B	3.1 B	3.1.B	
4. Tensile test at room temperature: One specimen to DIN 17 449, Table 9	3.1.B	3.1.C	3.1.B	
5. Visual inspection and dimensional check: Each component; surface condition in acc. with manufacturer's specification	3.1.B	3.1.C	3.1.B	
6. Material identification check: Each component, e.g. by spectroscopy	3.1.B	3.1.B	3.1.B	
Material identification: Manufacturer's mark, steel grade, melt number, specimen number, inspector's mark				
1) Only if components are welded and are in contact with water.				

Materials test sheet 9: Bars and forgings made of austenitic steels to DIN 17 440

MATERIALS TEST SHEET		WPB 9		
Load attaching points				
Product form: Bars and forgings				
Materials: Austenitic steels to DIN 17 440				
Requirements: DIN 17 440				
Tests and inspections	Certificate to DIN EN 10 204 for			
	additional requirements to Section 4.2	increased requirements to Section 4.3	core components to Section 4.4	
1. Chemical composition: Ladle analysis	2.2	3.1.B	3.1.B	
2. Heat treatment condition	2.2	2.2	2.2	
3. Check for intergranular corrosion resistance ¹⁾ : One specimen per melt and heat treatment batch each	3.1.B	3.1 B	3.1.B	
4. Tensile test at room temperature: One specimen to DIN 17 440, Table 9 (special requirements)	3.1.B	3.1.C	3.1.B	
5. Visual inspection and dimensional check: Each component; surface condition in acc. with manufacturer's specification	3.1.B	3.1.C	3.1.B	
6. Material identification check: Each component, e.g. by spectroscopy	3.1.B	3.1.B	3.1.B	
7. Ultrasonic testing: For bar steel with product thicknesses ≥ 30 mm and forgings ≥ 300 kg each component subject to 100 % in acc. with Annex B	3.1.B	3.1.C		
Material identification: Manufacturer's mark, steel grade, melt number, specimen number, inspector's mark				
¹⁾ Only if components are welded and are in contact with water.				

Materials test sheet 10: Seamless tubes made of austenitic steels to DIN 17 458

MATERIALS TEST SHEET		WPB 10
Load attaching points		
Product form:	Seamless tubes	
Materials:	Austenitic stainless steels to DIN 17 458	
Requirements:	DIN 17 458 (test category 2)	
Tests and inspections	Certificate to DIN EN 10 204 for	
	additional requirements to Section 4.2	increased requirements to Section 4.3
1. Chemical composition: Ladle analysis	2.2	3.1.B
2. Heat treatment condition	2.2	2.2
3. Check for intergranular corrosion resistance ¹⁾ : One specimen per melt and heat treatment batch each	3.1.B	3.1 B
4. Tensile test at room temperature: Lot size and extent of testing in acc. with DIN 17 458, Table 7	3.1.B	3.1.C
5. Technological test procedures: Type and extent of testing in acc. with DIN 17 458, Tables 7 and 8	3.1.B	3.1.C
6. Visual inspection and dimensional check: Each tube, surface condition in acc. with manufac- turer's specification	3.1.B	3.1.C
7. Material identification check: Each tube, e.g. by spectroscopy	3.1.B	3.1.B
8. Non-destructive testing: Type and extent of testing in acc. with DIN 17 458, Table 7 ser. no. 10	3.1.B	3.1.B
Material identification: Manufacturer's mark, steel grade, melt number, specimen number, inspector's mark		
1) Only if components are welded and are in contact with water.		

Materials test sheet 11: Austenitic cast steel to DIN 17 445

MATERIALS TEST SHEET		WPB 11		
Load attaching points				
Product form: Cast steel				
Materials: Austenitic cast steel to DIN 17 445				
Requirements: DIN 17 445				
Tests and inspections	Certificate to DIN EN 10 204 for			
	additional requirements to Section 4.2	increased requirements to Section 4.3	core components to Section 4.4	
1. Chemical composition: Ladle analysis	2.2	3.1.B	3.1.B	
2. Heat treatment condition	2.2	2.2	2.2	
3. Check for intergranular corrosion resistance ¹⁾ : One specimen per melt and heat treatment batch each	3.1.B	3.1.B	3.1.B	
4. Tensile test at room temperature: One specimen per melt and heat treatment batch each; test lot: 2500 kg	3.1.B	3.1.C	3.1.B	
5. Notched bar impact test at room temperature: One set of impact test specimens per tensile test specimen	3.1.B	3.1.C	3.1.B	
6. Visual inspection and dimensional check: Each component; surface condition in acc. with manufacturer's specification	3.1.B	3.1.C	3.1.B	
7. Material identification check: Each component, e.g. by spectroscopy	3.1.B	3.1.B	3.1.B ²⁾	
8. Non-destructive testing to DIN 1690-2: Quality grades for NDT and extent of volumetric test- ing shall be indicated by the purchaser and be fixed within design approval.	3.1.B	3.1.C	3.1.B	
Material identification: Manufacturer's mark, steel grade, melt number, specimen number, inspector's mark				
¹⁾ Only if components are welded and are in contact with water.				

Materials test sheet 12: Bolts and nuts to DIN EN 20 898-1, DIN EN 20 898-2 and DIN ISO 3269

MATERIALS TEST SHEET		WPB 12	
Load attaching points			
Product form:	Bolts and nuts \leq M 39		
Materials:	Strength classes Bolts 4.6, 5.6, 6.8, 8.8 and 10.9 Nuts 4, 5, 6, 8 and 10		
Requirements:	Bolts: DIN EN 20 898-1, DIN ISO 3269 Nuts: DIN EN 20 898-2, DIN ISO 3269		
Tests and inspections	Certificate to DIN EN 10 204 for		
	additional requirements to Section 4.2	increased requirements to Section 4.3	
Proof (by continuous recording in the manufacturer's works) that the requirements regarding mechanical properties, surface condition and dimensional accuracy have been met	2.2 ¹⁾	2.2 ¹⁾	
Material identification: Bolts in acc. with DIN EN 20 898-1 Nuts in acc. with DIN EN 20 898-2			
¹⁾ In lieu of the test report stamping will suffice if the manufacturer has been examined by the authorized inspector in acc. with VdTÜV-Merkblatt 1253/4, however, not for bolts of strength classes 8.8 and 10.9 and nuts of strength classes 8 and 10.			

Materials test sheet 13: Bolts and nuts made of austenitic steels to DIN EN ISO 3506-1, DIN EN ISO 3506-2 and DIN ISO 3269

MATERIALS TEST SHEET		WPB 13		
Load attaching points				
Product form:	Bolts and nuts \geq M 10 and \leq M 39			
Materials:	Strength classes 50, 70 and 80 Steel group: A2 and A4			
Requirements:	DIN EN ISO 3506-1, DIN EN ISO 3506-2, DIN ISO 3269			
Tests and inspections	Certificate to DIN EN 10 204 for			
	additional requirements to Section 4.2	increased requirements to Section 4.3	core components to Section 4.4	
Proof (by continuous recording in the manufacturer's works) that the requirements regarding mechanical properties, surface condition and dimensional accuracy have been met	2.2 ¹⁾	2.2 ¹⁾	2.2 ¹⁾	
Material identification: In acc. with DIN EN ISO 3506-1, DIN EN ISO 3506-2				
¹⁾ In lieu of the test report stamping will suffice if the manufacturer has been examined by the authorized inspector in acc. with VdTÜV-Merkblatt 1253/4.				

Materials test sheet 14: Bolts and studs, thread rolled, head bolts with forged-on head, and subsequently heat-treated

MATERIALS TEST SHEET		WPB 14
Load attaching points		
Product form: Bolts and studs, thread rolled, head bolts with forged-on head, heat-treated		
Materials: DIN EN 10 083-1, DIN 17 240, 1.4313 V2 SEW 400		
Requirements: DIN EN 10 083-1, DIN 17240, DIN ISO 3269, DIN EN 26 157-1, DIN EN 20 898-1, SEW 400 and supplementary sheet to this materials test sheet		
Tests and inspections	Certificate to DIN EN 10 204	
	additional requirements to Section 4.2	for increased requirements to Section 4.3
1. Tests on basic material (bar)		
1.1 Chemical composition: Ladle analysis	2.2	3.1.B
1.2 Materials identification check for alloyed steels: Each bar	2.2	3.1.B
1.3 Ultrasonic testing: For bars with thicknesses ≥ 30 mm each component in acc. with Annex B	3.1 B	3.1.C
2. Tests on finished parts:		
2.1 Heat treatment condition	3.1 B	3.1.B
2.2 Hardness test for verification of uniform heat treatment on 10 % of all bolts and studs	3.1.B	3.1 B
2.3 Tensile test at room temperature: Number of test specimen sets to DIN ISO 3269 and supplementary sheet to this materials test sheet ¹⁾	3.1. B	3.1.C
2.4 Notched bar impact test at room temperature: In the case of bolts and studs $\geq M16$ one set of impact test specimen per tensile test specimen	3.1. B	3.1.C
2.5 Surface crack detection: Each bolt or stud; procedure and evaluation based on DIN EN 26 157-1	3.1. B	3.1.C
2.6 Visual inspection and dimensional check: In acc. with DIN ISO 3269 (number of random samples: 20) ¹⁾	3.1. B	3.1.C
2.7 Test of edge decarburization ²⁾ : Based on DIN EN 20 898-1 Number of specimens to DIN ISO 3269 and supplementary sheet to this materials test sheet ¹⁾	3.1. B	3.1.B
Material identification: Manufacturer's mark, steel grade, melt number, inspector's mark		
¹⁾ All specimens shall meet the requirements (acceptance number $A_C = 0$).		
²⁾ Not required for material 1.4313.		

Supplementary sheet to materials test sheet WPB 14: Sampling plan for destructive testing of mechanical properties

Number of pieces	Number of specimen sets for mechanical testing
≤ 200	1
> 200 up to ≤ 400	2
> 400 up to ≤ 800	3
> 800 up to ≤ 1200	4
> 1200 up to ≤ 1600	5
> 1600 up to ≤ 3000	6
> 3000 up to ≤ 3500	7
> 3500	DIN ISO 3269

If it is proved that the bolts and studs delivered are of the same melt and heat treatment testing of 4 specimen sets irrespective of the number of pieces will suffice.

Materials test sheet 15: Welded tubes made of austenitic steels to DIN 17 457

MATERIALS TEST SHEET		WPB 15
Load attaching points		
Product form:	Welded tubes	
Materials:	Austenitic stainless steels to DIN 17 457	
Requirements:	DIN 17 457 (test category 2)	
Tests and inspections	Certificate to DIN EN 10 204 for	
	additional requirements to Section 4.2	increased requirements to Section 4.3
1. Chemical composition: Ladle analysis	2.2	3.1.B
2. Heat treatment condition	2.2	2.2
3. Check for intergranular corrosion resistance ¹⁾ : One specimen per melt and heat treatment batch each	3.1.B	3.1.B
4. Tensile test at room temperature: Lot size and extent of testing in acc. with DIN 17 457, Table 7	3.1.B	3.1.C
5. Technological test procedures: Type and extent of testing acc. to DIN 17 457, Tables 7 and 8	3.1.B	3.1.C
6. Visual inspection and dimensional check: Each tube; surface condition in acc. with manufac- turer's specification	3.1.B	3.1.C
7. Material identification check: Each tube, e.g. by spectroscopy	3.1.B	3.1.B
8. Non-destructive testing: Type and extent of testing acc. to DIN 17 457, Table 7 ser. no. 9	3.1.B	3.1.C
Material identification: Manufacturer's mark, steel grade, melt number, specimen number, inspector's mark		
1) Only if components are welded and are in contact with water.		

Materials test sheet 16: Bars and forgings made of stainless martensitic and austenitic-ferritic steels to DIN 17 440 or SEW 400

MATERIALS TEST SHEET		WPB 16
Load attaching points		
Product form: Bars and forgings		
Materials: 1.4057, 1.4122, 1.4313, 1.4462		
Requirements: DIN 17 440, SEW 400		
Tests and inspections	Certificate to DIN EN 10 204 for	
	additional requirements to Section 4.2	increased requirements to Section 4.3
1. Chemical composition: Ladle analysis	2.2	3.1.B
2. Heat treatment condition (for 1.4313 indication of strength grade)	3.1.B	3.1.B
3. Tensile test at room temperature: Test lot and extent of testing to DIN 17 440, Table 9, or SEW 400, Table 7 (special requirements)	3.1.B	3.1.C
4. Notched bar impact test at room temperature: Test lot and extent of testing as for tensile test (only for nominal dimension ≥ 15 mm)	3.1.B	3.1.C
5. Visual inspection and dimensional check: Each component, surface quality and dimensions in acc. with manufacturer's specification	3.1.B	3.1.C
6. Material identification check: Each component, e.g. by spectroscopy	3.1.B	3.1.B
7. Ultrasonic testing: For bar steel with product thicknesses ≥ 30 mm and forgings ≥ 300 kg each component subject to 100 % in acc. with Annex B	3.1.B	3.1.C
Material identification: Manufacturer's mark, steel grade, melt number, specimen number, inspector's mark		

Materials test sheet 17: Plates, sheets and strips made of zirconium alloys

MATERIALS TEST SHEET		WPB 17
Load attaching points		
Product form: Plates, sheets and strips with thicknesses $s \leq 4.7$ mm		
Materials: Zirconium alloys Grade R60802 or Grade R60804		
Requirements: ASTM B 352 - 92		
Tests and inspections	Certificate to DIN EN 10 204 for core components to Section 4.4	
1. Chemical composition:		
1.1 On the ingot (ladle analysis) One specimen of head, middle and tail of each ingot	3.1.B	
1.2 On the plate, sheet or strip (product analysis) One specimen per lot (considered to be a material identification check)	3.1.B	
2. Tensile test at room temperature: One specimen in longitudinal and transverse direction each per lot in acc. with DIN EN 10 002-1 or ASTM E 8 - 96a ¹⁾ and ASTM E 21 - 92	3.1.B	
3. Corrosion resistance Two specimens per lot to ASTM G 2 - 88	3.1.B	
4. Visual inspection and dimensional check: Each component, surface quality and dimensions in acc. with manufacturer's specification	3.1.B	
Material identification: Identification marking, melt or ingot number, lot number, if any, specimen number or plate, sheet, strip number respectively		
¹⁾ or ASTM E 8 M - 96a		

Materials test sheet 18: Forged bars and open-die forgings made of weldable fine grain structural steel to DIN 17 103

MATERIALS TEST SHEET		WPB 18
Load attaching points		
Product form: Forged bars and open-die forgings		
Materials: TStE 355 (1.0566), TStE 420 (1.8912), TStE 460 (1.8915), TStE 500 (1.8917)		
Requirements: DIN 17 103		
Tests and inspections	Certificate to DIN EN 10 204 for	
	additional requirements to Section 4.2	increased requirements to Section 4.3
1. Chemical composition: Ladle analysis	2.2	3.1.B
2. Heat treatment condition	3.1.B	3.1.B
3. Tensile test at room temperature: Test lot and extent of testing to DIN 17 103, Table 8	3.1.B	3.1.C
4. Notched bar impact test at test temperature to DIN 17 103, clause 9.4.4: Test lot and extent of testing as for tensile test (only for nominal dimension ≥ 15 mm)	3.1.B	3.1.C
5. Visual inspection and dimensional check: Each component, surface quality and dimensions in acc. with manufacturer's specification	3.1.B	3.1.C
6. Material identification check: Each component, e.g. by spectroscopy	3.1.B	3.1.B
7. Ultrasonic testing: For bar steel with product thicknesses ≥ 30 mm and forgings ≥ 300 kg each component subject to 100 % in acc. with Annex B	3.1.B	3.1.C
Material identification: Manufacturer's mark, steel grade, melt number, specimen number, inspector's mark		

Annex B

Non-destructive testing (NDT)

Contents

- B 1 Scope

- B 2 General specifications for non-destructive testing
 - B 2.1 Personnel
 - B 2.2 Equipment and test fluids
 - B 2.3 Point in time of NDT

- B 3 NDT procedural requirements
 - B 3.1 Magnetic particle testing
 - B 3.2 Liquid penetrant testing
 - B 3.3 Radiography
 - B 3.4 Ultrasonic testing

- B 4 Performance and evaluation of tests on ferritic product forms
 - B 4.1 Bars
 - B 4.2 Bolts and trunnions
 - B 4.3 Open-die forged parts

- B 5 Performance and evaluation of tests on austenitic product forms (rolled or forged components)
 - B 5.1 Surface crack detection
 - B 5.2 Ultrasonic testing

- B 6 Performance and evaluation of tests on ferritic welds
 - B 6.1 Ultrasonic testing of weld junction areas for plates under tensile loading in thickness direction
 - B 6.2 Surface crack detection of welds
 - B 6.3 Radiography of welds
 - B 6.4 Ultrasonic testing of welds

- B 7 Performance and evaluation of tests on austenitic welds
 - B 7.1 Surface crack detection
 - B 7.2 Radiography

B 1 Scope

(1) This Annex applies to the performance of non-destructive tests and contains procedural requirements and evaluation criteria for non-destructive testing.

(2) Deviations from this Annex may be possible in justified individual cases.

Note:

The procedure, extent and point in time of NDT shall be laid down in materials test sheets and in-process test and inspection sequence plans.

B 2 General specifications for non-destructive testing**B 2.1 Personnel****B 2.1.1 Test supervisors**

(1) The manufacturer shall notify the test supervisor to the authorized inspector. Regarding the manufacturer's organization, test supervisors shall be independent of the manufacturing department. Test supervisors shall have the knowledge required for performing their tasks and shall have basic knowledge of production processes and shall know the application limits and possibilities of the test procedures. In addition, test supervisors shall be capable of performing the test described in the following clauses and shall be responsible for the proper condition of the test equipment. They shall also ensure that the test instructions to be established by the manufacturer are adhered to.

(2) Test supervisors shall ensure that only qualified personnel is employed and shall supervise the test to be performed by the manufacturer, evaluate the test results and sign the test report.

B 2.1.2 NDT Operators

(1) NDT operators shall be able to perform the tests described in the following clauses, to adjust the test equipment and to establish the test records.

(2) This knowledge shall be proved to the test supervisor even if operators not in the employ of the manufacturer are employed.

(3) The NDT operators shall prove that they have adequate vision in conformance with DIN EN 473.

B 2.2 Equipment and test fluids

(1) For the performance of non-destructive tests equipment and fluids shall be used which are suited for the respective purposes.

(2) The test systems shall conform to the state-of-the-art.

B 2.3 Point in time of NDT

The product forms shall be tested by the manufacturer in the as-delivered condition and welds in the final-heat treatment condition, where possible.

B 3 NDT procedural requirements**B 3.1 Magnetic particle testing****B 3.1.1 General requirements**

The various possibilities of magnetization shall be taken from DIN 54 130.

B 3.1.2 Requirements for equipment and test fluids

(1) Where magnetization is effected by the magnetic flux method, suitable measures shall be taken to ensure that arc striking is avoided during the test as far as possible.

(2) To this end, the test may be carried out e.g. with consumable electrodes or with the aid of contact pads.

(3) The test fluid shall wet the test surface and shall not cause any corrosive damage. Additional rust preventing agents are permitted if they do not adversely effect the test result.

(4) The test fluid shall make the detection of defects possible; if required, a suitable contrast aid shall be used.

(5) The test fluid shall be randomly controlled on the magnetized part, e.g. by Berthold field indicators.

B 3.1.3 Surface condition

The test surfaces shall be cleaned and be free from disturbing impurities. Unless particular requirements are specified in the clauses referring to materials and product forms, the root mean square R_a to DIN EN ISO 4287 shall not exceed a value of 20 μm .

B 3.1.4 Performance**B 3.1.4.1 Direction of magnetization**

All surfaces shall be tested using two different directions of magnetization which shall be offset by 90 degrees, where possible. It shall be ensured that the field directions are not outside an angular range between 50 and 130 degrees.

B 3.1.4.2 Magnetic field strength

The tangential field strength shall be between $2 \cdot 10^3$ A/m and $6.5 \cdot 10^3$ A/m. Compliance with these values shall be controlled by means of suitable measuring instruments, or test conditions shall be determined under which these values can be obtained.

Note:

Possibilities of verifying the sufficient magnetization of the test object are given in the guideline of DGZfP - Deutsche Gesellschaft für zerstörungsfreie Prüfverfahren e.V., Berlin, DGZfP-EM-3: "Instruction sheet for the control of parameters in magnetic particle testing".

B 3.1.4.3 Contact spots

Arc strikes shall be removed and be subjected to a liquid penetrant test or a magnetic particle test using the yoke magnetization technique.

B 3.1.4.4 Duration of magnetization

(1) The following times shall be adhered to:

Magnetization and wetting: at least 3 seconds

Re-magnetization: at least 3 seconds

(2) The evaluation shall be made during re-magnetization.

B 3.2 Liquid penetrant testing**B 3.2.1 Requirements to be met by penetrants**

(1) The suitability of the test system (liquid penetrant, intermediate cleaning agent and developer) shall be demonstrated to the authorized inspector by a model test to DIN 54 152-2.

(2) Suitable measures shall be taken to ensure that the properties of the test system as specified under (1) are maintained.

B 3.2.2 Surface condition

The surface condition shall meet the requirements specified under B 3.1.3.

B 3.2.3 Performance

(1) Liquid penetrant testing shall be performed in accordance with DIN 54 152-1 and the following requirements.

(2) The penetration time shall be at least half an hour.

(3) As soon as possible after drying of the developer, the first inspection should take place. A further inspection shall be performed at the earliest half an hour after the first inspection.

(4) Further points in time of inspection are required if crack-like indications are detected by the second inspection which were not discernible after the first inspection.

Note:

Further points in time of inspection may be necessary if during the second inspection essential changes or additional indications are detected.

(5) The evaluation shall be made in due consideration of all inspection results.

B 3.3 Radiography

Test class A to DIN EN 1435 shall be adhered to unless test class B has been fixed in the test and inspection sequence plans. The image quality levels in accordance with image quality class A to DIN EN 462-3 shall be adhered to.

B 3.4 Ultrasonic testing

B 3.4.1 Requirements for test frequencies and transducer (crystal) dimension

The test frequency, transducer dimension and scanning positions are laid down in Sections B 4 to B 6. These specifications are considered guide values from which deviations are possible in justified cases.

B 3.4.2 Surface condition

The test surfaces shall be free from rust, scale, weld spatter, and other impurities which may interfere with the probe-to-specimen contact and shall be in a condition suited for the test purpose. Regarding the root mean square R_a to DIN EN ISO 4287 of the test surface and the opposite surface a value equal to or smaller than 20 μm should be obtained.

B 3.4.3 Performance

B 3.4.3.1 Test instructions

For the ultrasonic testing of components with complex geometry impairing the performance of the test the details shall be laid down in test instructions and be agreed with the authorized inspector.

B 3.4.3.2 Setting of sensitivity (examination levels)

The sensitivity shall be set on the test object, on reference block K1 to DIN 54 120 or on calibration block No. 2 to DIN EN 27 693 or on equivalent reference blocks of the same geometry by using suitable reference reflectors. Reference reflectors may be back walls, grooves and boreholes. The ref-

erence block dimensions should not differ by more than 10 % from the test piece dimensions.

B 3.4.3.3 Adaptation of the probe to curved surfaces

The probe shall be centred in the probe index area. The distance between the probe base and the test surface should not exceed 0.5 mm at any point. If required, the probe base shall be adapted accordingly (see **Figure B-1**).

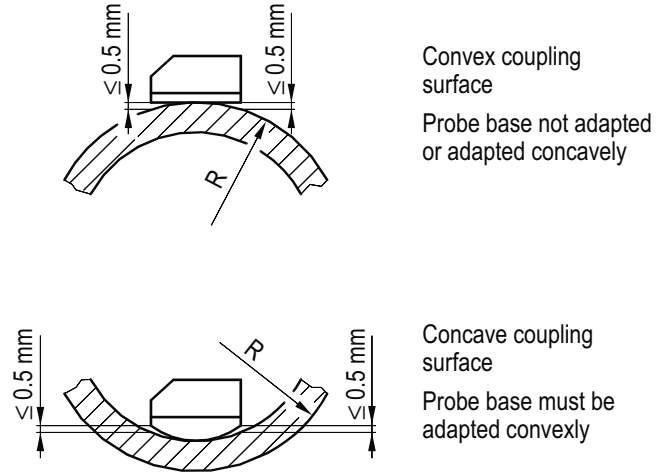

Figure B-1: Adaptation of probe base to curved surfaces

B 4 Performance and evaluation of tests on ferritic product forms

B 4.1 Bars

B 4.1.1 Surface crack detection

B 4.1.1.1 Performance

(1) The entire surface shall be tested in its finished condition. Magnetic particle testing shall be used preferably.

(2) Magnetic particle testing shall be performed in accordance with B 3.1.

(3) Liquid penetrant testing shall be performed in accordance with B 3.2.

B 4.1.1.2 Evaluation of magnetic particle test and liquid penetrant test

(1) Indications with a maximum extension equal to or smaller than 1.5 mm detected by magnetic particle testing and indications equal to or smaller than 3 mm detected by liquid penetrant testing shall not be included in the evaluation. Larger indications from which the presence of cracks can be concluded are not permitted. Indications proved to be non-metallic inclusions as well as rounded indications up to an extension of 6 mm are permitted.

(2) The frequency of permissible indications may be locally limited to a number of ten on an area of 100 mm • 100 mm. In the case of larger dimensions or frequency these areas shall be repaired or agreement shall be reached with the authorized inspector on the acceptability of the component.

B 4.1.2 Ultrasonic testing

B 4.1.2.1 Performance

Section B 3.4 applies to the performance of ultrasonic testing.

B 4.1.2.2 Scanning positions and conditions and evaluation for round bars

- (1) The scanning positions for round bars are shown in **Figure B-2**.
- (2) Straight beam scanning shall be effected in positions 1, 2 and 3. For round bars with a diameter d equal to or smaller than 60 mm position 3 will suffice. For bar lengths l greater than 2a and diameters d greater than 60 mm angle beam scanning shall additionally be performed on three paths offset by 120 degrees.
- (3) The scanning conditions shall be taken from **Table B-1**.
- (4) The evaluation shall be made in accordance with **Table B-2**.

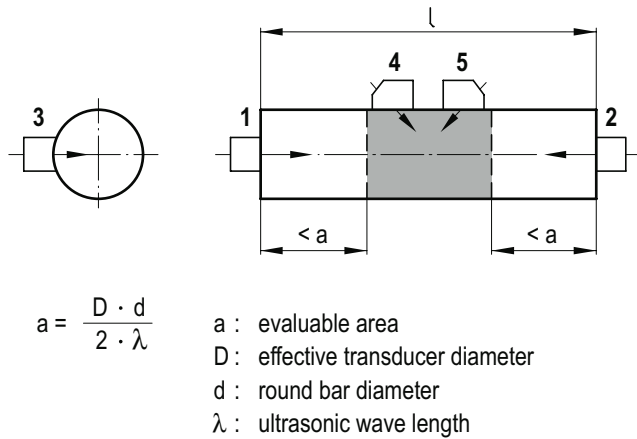

Figure B-2: Scanning positions for round bars

B 4.1.2.3 Scanning positions and conditions, evaluation for rectangular or polygonal bars

- (1) The scanning positions are shown in **Figure B-3**.

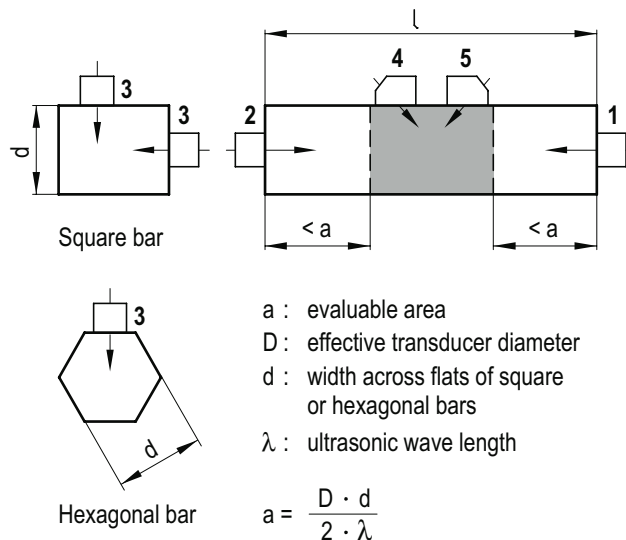

Figure B-3: Scanning positions for rectangular or polygonal bars

- (2) Straight beam scanning shall be effected in positions 1, 2 and 3, in the latter case, on three paths offset by 120 degrees (hexagonal bar) or on two paths offset by 90 degrees (rectangular bar). For rectangular or polygonal bars with d equal to or smaller than 60 mm position 3 will suffice. For bar lengths l greater than 2a and widths across flats d greater

than 60 mm scanning shall additionally be performed on three paths offset by 120 degrees (hexagonal bar) or on two paths offset by 90 degrees (rectangular bar). For other polygonal bars scanning shall be effected accordingly.

- (3) The scanning conditions shall be taken from **Table B-3**.
- (4) The evaluation shall be made in accordance with **Table B-4**.

B 4.2 Bolts and trunnions

B 4.2.1 Surface crack detection

Surface crack detection tests shall be performed and evaluated in accordance with B 4.1.1.

B 4.2.2 Ultrasonic testing

B 4.2.2.1 Extent and point in time of testing

The test shall be performed in a state of simple geometry in which case the full volume shall be tested. Edges with weld preparation, if any, shall be indicated for testing.

B 4.2.2.2 Scanning positions

The parts shall be tested such that each volumetric area is tested from at least two scanning positions offset by approximately 90 degrees. If this cannot be done by straight beam scanning, angled beam scanning shall be used.

B 4.2.2.3 Scanning conditions

- (1) For rough-turned cylindrical non-stepped bolts and trunnions the scanning positions of B 4.1.2.2 shall apply.
- (2) **Figure B-4** shows examples of rough-turned stepped bolts and trunnions.
- (3) Where the scanning conditions of subparas 1 and 2 do not suffice, test instructions shall be established.

B 4.2.2.4 Evaluation

The evaluation shall be made in accordance with **Table B-2**.

B 4.3 Open-die forged parts

Test instructions shall be performed for the performance and evaluation of ultrasonic tests.

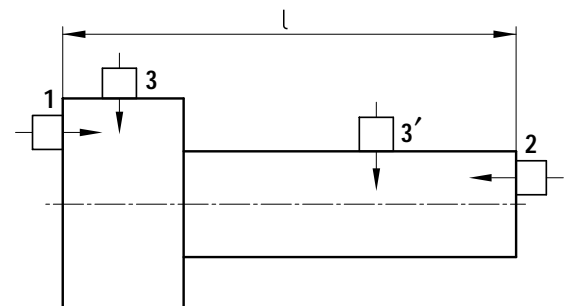

Figure B-4: Scanning positions for rough-turned stepped bolts and trunnions (examples)

d, mm	Scanning positions	Angle of refraction, degrees	Frequency, MHz
30 < d ≤ 60	3	0	4
60 < d ≤ 120	1 to 3	0	4
	4 and 5	70	4
d > 120	1 and 2	0	4
	3	0	2 to 4
	4 and 5	70	2 to 4

Where the bar length exceeds 2a and the diameter is greater than 60 mm, ultrasonic testing shall be performed at scanning positions 4 and 5 in the hatched area as shown in **Figure B-2** with half the skip distance (single traverse technique).

Table B-1: Scanning conditions for round bars

Scanning positions	1 and 2		3	4 and 5
Reference reflector	Component back-wall or K 1	Component backwall or reference block	Component backwall or K 1	K 1 / No. 2
Dimension	—	Length < a	$d \geq \frac{D^2}{\lambda}$	R 100/ R 25
Evaluation method	DGS	DGS	DGS	DGS
Recording limit	60 < d ≤ 120: CDR 4 d > 120: CDR 6	60 < d ≤ 120: CDR 4 d > 120: CDR 6	d ≤ 60: CDR 3 60 < d ≤ 120: CDR 4 d > 120: CDR 6	CDR 3
Permissible excess of the echo amplitude over the recording limit, dB	6	6	6	6
Permissible half-amplitude length ¹⁾	locally	locally	≤ d, maximum 50	locally
Allowable frequency of indication per metre	5	5	d ≤ 60 : 3 d > 60 : 5	5

¹⁾ When evaluating the half-amplitude length of reflectors, the probe displacement at a signal amplitude drop of 6 dB to the maximum echo height shall be determined.

Table B-2: Evaluation of ultrasonic test on round bars

Width across flats	Scanning positions	Angle of refraction, degrees	Frequency, MHz
30 < d ≤ 60	3	0	4
d > 60	1 and 2	0	4
	3	0	2 to 4
	4 and 5	70	2 to 4

Where the bar length exceeds 2a and the width across flats d according to **Figure B-3** is greater than 60 mm, ultrasonic testing shall be performed at scanning positions 4 and 5 in the hatched area as shown in Figure B-3 for rectangular bars on two paths offset by 90 degrees or for polygonal bars on three paths offset by 60 degrees with half the skip distance (single traverse technique). For other polygonal bars testing shall be performed accordingly.

Table B-3: Scanning conditions for rectangular or polygonal bars

Scanning positions	1 and 2		3	4 and 5
Reference reflector	Component backwall or K 1	Component backwall or reference block	Component backwall or K 1	K 1 / No. 2
Dimension	—	Length < a	$c \geq \frac{2 \cdot d \cdot \lambda}{D}$ c = edge length d = dimension in scanning direction	R 100/ R 25
Evaluation method	DGS	DGS	DGS	DGS
Recording limit	60 < d ≤ 120: CDR 4 d > 120: CDR 6	60 < d ≤ 120: CDR 4 d > 120: CDR 6	d ≤ 60: CDR 3 60 < d ≤ 120: CDR 4 d > 120: CDR 6	CDR 3
Permissible excess of echo amplitude over the recording limit, dB	6	6	6	6
Permissible half-amplitude length ¹⁾	locally	locally	≤ d, maximum 50	locally
Allowable frequency of indication per metre	5	5	d ≤ 60 : 3 d > 60 : 5	5

¹⁾ When evaluating the half-amplitude length of reflectors, the probe displacement at a signal amplitude drop of 6 dB to the maximum echo height shall be determined.

Table B-4: Evaluation of ultrasonic test on rectangular or polygonal bars

B 5 Performance and evaluation of tests on austenitic product forms (rolled or forged components)

B 5.1 Surface crack detection

- (1) The entire surface shall be tested in its finished condition.
- (2) The tests shall be performed in accordance with B 3.2.
- (3) The evaluation shall be made in accordance with B 4.1.1.2.

B 5.2 Ultrasonic testing

B 5.2.1 Extent and point in time of testing

The test shall be performed in a state of simple geometry, in which case the full volume shall be tested.

B 5.2.2 Scanning directions and frequencies

The components shall be tested such that each volumetric area is tested by straight beam scanning from at least two scanning directions, if practicable, offset by approximately 90 degrees. The test frequencies may range from 0.5 to 4 MHz.

B 5.2.3 Evaluation

The evaluation shall be made in accordance with the specifications of Section B 4. If this criteria cannot be complied with, separate specifications shall be agreed with the authorized inspector.

B 6 Performance and evaluation of tests on ferritic welds

B 6.1 Ultrasonic testing of weld junction areas for plates under tensile loading in thickness direction

Ultrasonic testing of the weld junction areas shall be effected in accordance with SEL 072, class 0.

B 6.2 Surface crack detection of welds

B 6.2.1 Performance

- (1) Surface crack detection shall be performed in accordance with B 3.1 or B 3.2.
- (2) As far as practicable, magnetic particle testing shall be performed.
- (3) The adjacent base metal areas shall be covered by the test up to a width of 20 mm.

B 6.2.2 Evaluation

(1) Indications with a maximum extension equal to or smaller than 1.5 mm detected by magnetic particle testing and indications equal to or smaller than 3 mm detected by liquid penetrant testing shall not be included in the evaluation. Larger indications from which the presence of cracks can be concluded are not permitted. Indications proved to be non-metallic inclusions as well as rounded indications up to an extension of 6 mm are permitted.

(2) The frequency of permissible indications may locally be up to 3 per 100 mm weld length. In the case of larger dimensions or frequency these locations shall be repaired or agreement shall be reached with the authorized inspector on the acceptability of the component.

B 6.3 Radiography of welds

B 6.3.1 Performance

Radiography shall be performed in accordance with B 3.3.

B 6.3.2 Evaluation

The evaluation of internal findings shall be made in accordance with DIN EN 25 817. The evaluation category shall be specified within the scope of design approval.

B 6.4 Ultrasonic testing of welds

B 6.4.1 General

- (1) The volume to be tested shall include the weld metal and the adjacent base metal on both sides over a width of
 - a) 10 mm on each side for wall thicknesses equal to or smaller than 30 mm,
 - b) 1/3 of the wall thickness on each side for wall thicknesses greater than 30 mm and smaller than 60 mm,
 - c) 20 mm on each side for wall thicknesses equal to or greater than 60 mm.
- (2) The volume to be tested shall be scanned from two different directions.

B 6.4.2 Butt welds

- (1) All butt welds shall be examined for presence of longitudinal defects.
- (2) The scanning positions are shown in **Figure B-5**. The test shall be performed from scanning positions 1 and 2 over the full skip distance. Where testing from this position is impracticable, it may be performed from scanning positions 1 and 3, and where this is impracticable, from position 1 - as shown in **Figure B-5**.
- (3) The scanning conditions shall be taken from **Table B-5**.
- (4) The evaluation shall be made in accordance with **Tables B-6** and **B-7**.

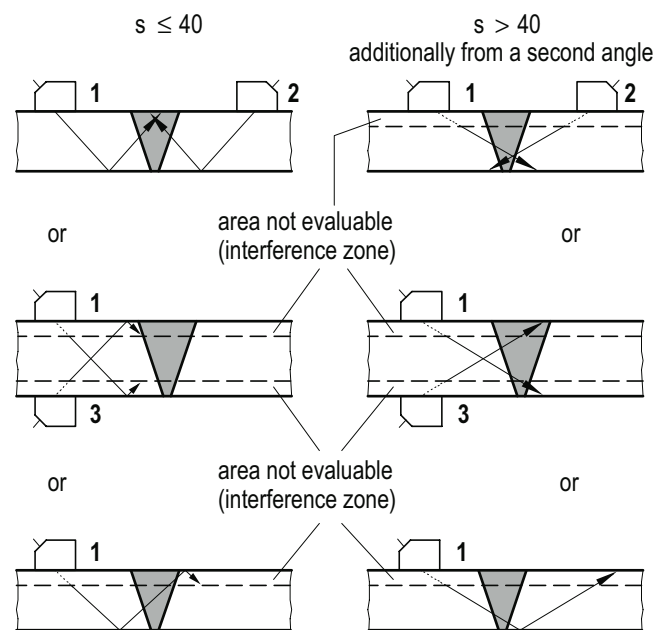

Figure B-5: Scanning positions for butt welds

(5) In the case of unacceptable indications, these indications may be proved to be unobjectionable by means of supplementary tests (radiography or test bores).

(6) Where echos are classified as geometry-related indications, this shall be proved by control measurements. For geometry-related indications this is deemed to have been proved if, upon scanning from the other side of the weld, the presumed location of the reflection does not produce any echo indication.

(7) Where, by measurement of the projection distances on the test piece, it shall be proved that the echos emanating from both sides of the weld are caused on the two faces of an unmachined weld root and not by weld defects, the exact projection distance shall be determined on reference reflectors. If the locations of the reflections are found to be distinctly separate from each other, the echo indications are considered to be geometry-related. Where a distance of less than 2 mm

is found, the reflections shall not be treated as separate reflections.

(8) Where evaluable reflections are produced by radiography, they shall be included in the evaluation.

B 7 Performance and evaluation of tests on austenitic welds

B 7.1 Surface crack detection

Surface crack detection shall be performed and evaluated in accordance with B 6.2.

B 7.2 Radiography

Radiography shall be performed and evaluated in accordance with B 6.3.

Wall thickness, mm	Scanning positions	Angle of refraction, degrees	Frequency, MHz
$15 \leq s \leq 40$	1 to 3	60 or 70	2 to 4
$s > 40$	1 to 3	60 or 70 and 45	2 to 4

Table B-5: Scanning conditions for butt welds

Scanning positions	1 to 3
Reference reflector	K 1, No. 2 or cylindrical bore with a diameter of 3 mm
Evaluation method	DGS or reference echo or DAC method
Recording limit	$15 \leq s \leq 40$: 50 % cylindrical bore or circular disk reflector CDR 2 $s > 40$: 50 % cylindrical bore or circular disk reflector CDR 3
Permissible excess of echo amplitude over the recording limit, dB	$s \geq 15$: $\begin{cases} 6 \text{ or} \\ 12 \text{ (one local indication per meter of weld)} \end{cases}$
Permissible frequency	in accordance with Table B-7
Permissible distances	For every two indications the distance of which is smaller than twice the length of the larger indication, the indication distance shall be covered by the evaluation. In this connection, particularly the orientation of the indications in relation to each other and in the weld, their reflection behaviour from different scanning directions and the wall thickness shall be taken into consideration. The following generally applies: a) Indications of the same depth ($< \pm 2.5$ mm) and the same width ($< \pm 5$ mm) located in the direction of welding shall have a distance from each other of at least the length of the longer indication. Otherwise, the indications are considered to be continuous. Where more than two indications follow each other closely, they shall be compared to each other in pairs and shall fulfil the above criteria. b) Indications of the same width ($< \pm 5$ mm) located in thickness direction shall have a distance at least exceeding half the length of the longer indication, but not less than 10 mm. c) Indication of the same depth ($< \pm 2.5$ mm) located side by side shall have a distance of at least 10 mm in the direction of width.

Table B-6: Evaluation of ultrasonic tests on butt welds

Length of indication ¹⁾ (Length category), mm	Maximum number of indications N_{imax} per m of weld					
	Nominal wall thickness s , mm					
	$10 < s \leq 20$	$20 < s \leq 40$	$40 < s \leq 60$	$60 < s \leq 120$	$120 < s \leq 250$	$250 < s$
Up to 10	17	19	21	23	25	27
Up to 15	12	14	16	18	20	22
Up to 20	8	10	12	14	16	18
Up to 25	6 ²⁾	8	10	12	14	16
Up to 30	4 ²⁾	6 ²⁾	8	10	12	14
Up to 35	1 ²⁾	4 ²⁾	6	8	10	12
Up to 40	—	1 ²⁾	4	6	8	10
Up to 45	—	—	2	4	6	8
Up to 50	—	—	1	3	5	7
Up to 55	—	—	—	2	4	6
Up to 60	—	—	—	1	3	5
Up to 65	—	—	—	—	2	4
Up to 70	—	—	—	—	1	3
Up to 75	—	—	—	—	—	2
Up to 80	—	—	—	—	—	1

The allowable number of indications per m of weld is obtained if the following condition is satisfied:

$$\sum \frac{N_i}{N_{imax}} = \frac{N_1}{N_{1max}} + \frac{N_2}{N_{2max}} + \dots + \frac{N_n}{N_{nmax}} \leq 1$$

N_i : Number of indications of equal length
 N_{imax} : Maximum allowable number of indications



¹⁾ When determining the indication lengths, the conditions of KTA 3201.3, 13.2.5.3.4 may be applied.
²⁾ Ultrasonic indications of reflectors with these lengths are only permitted if they are clearly identified as inclusion-type defects.

Table B-7: Reference values for the evaluation of ultrasonic tests

Annex C



Graphical representation of the delimitation between load attaching point and load for several examples

Note:

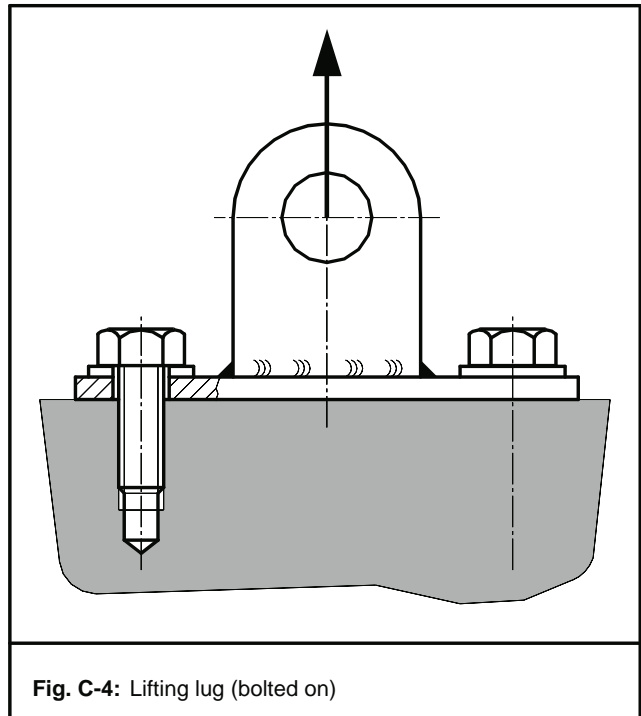
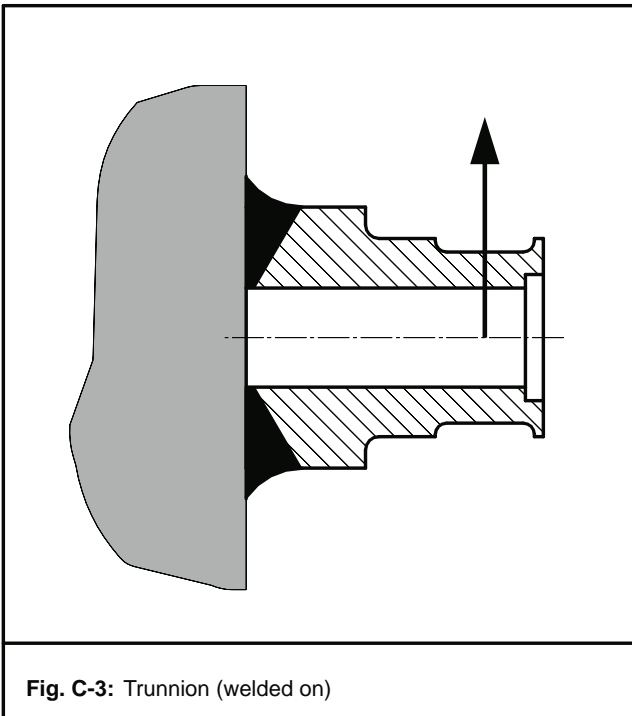
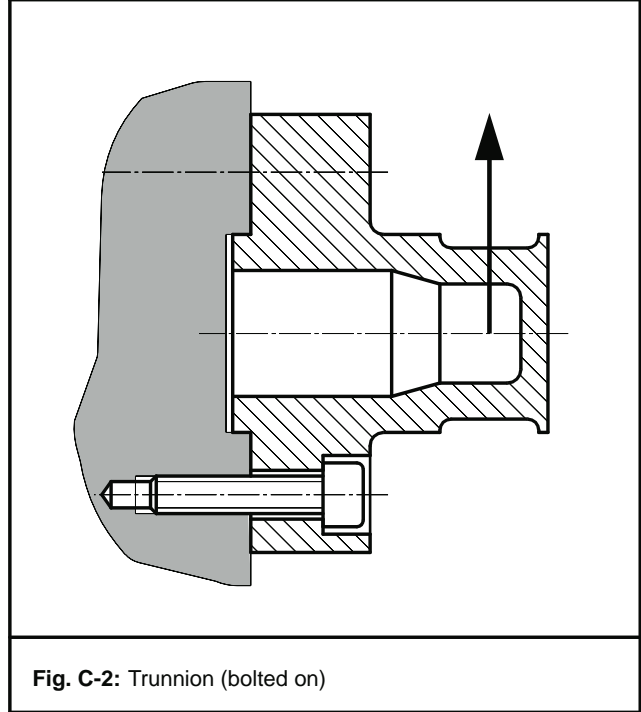
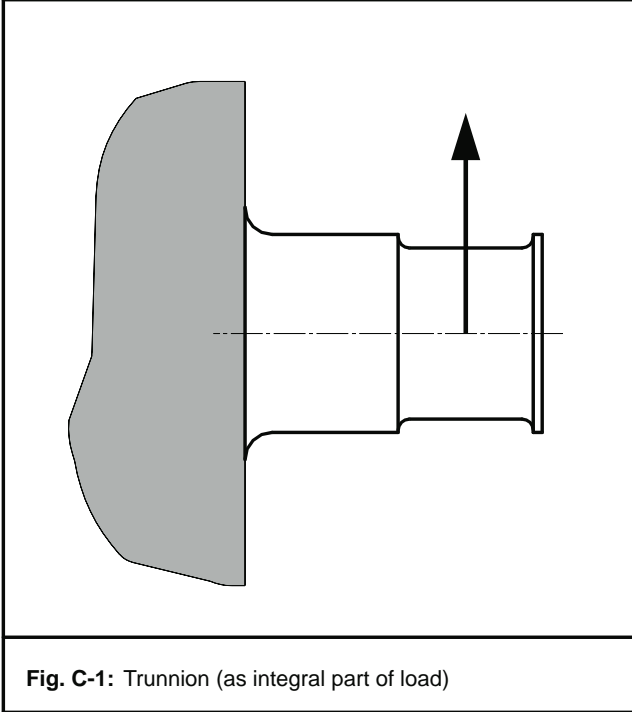
-  Load attaching point
-  Load



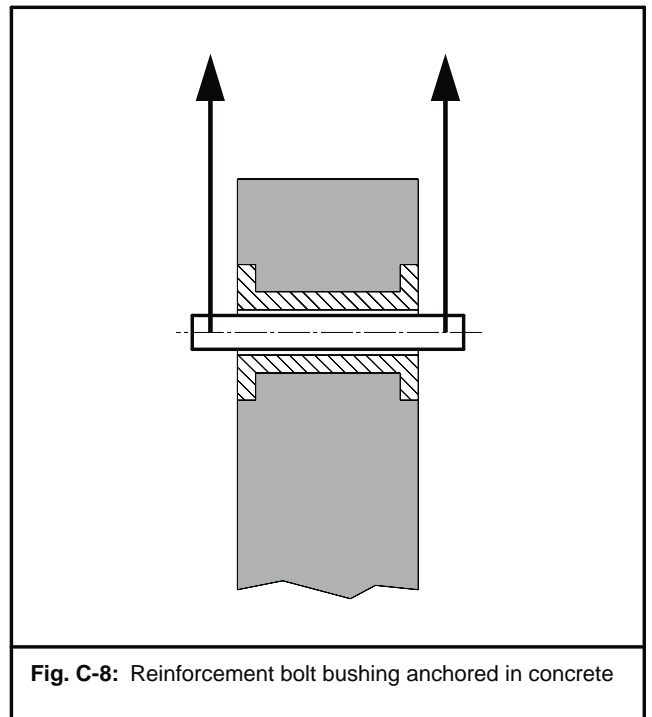
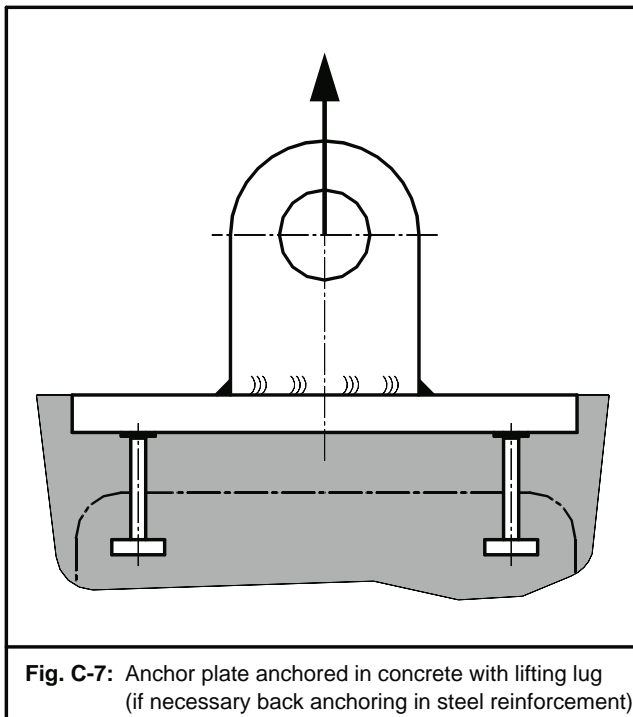
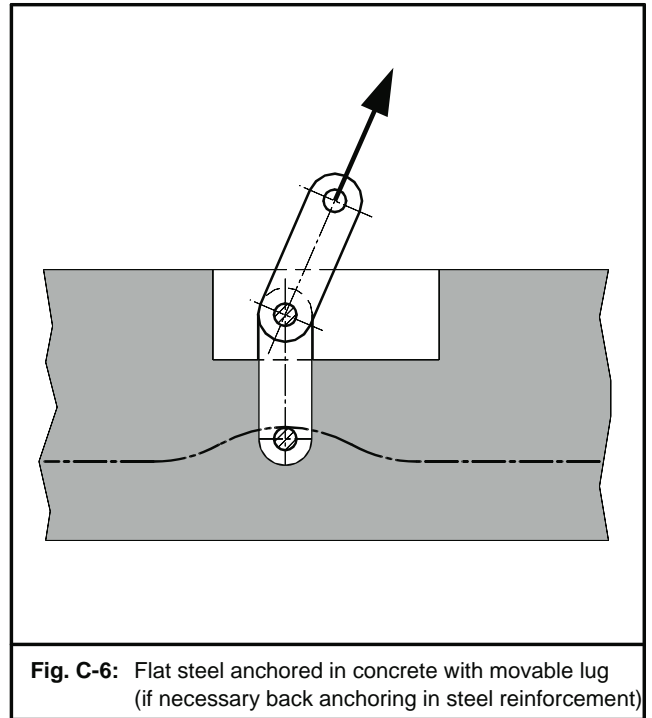
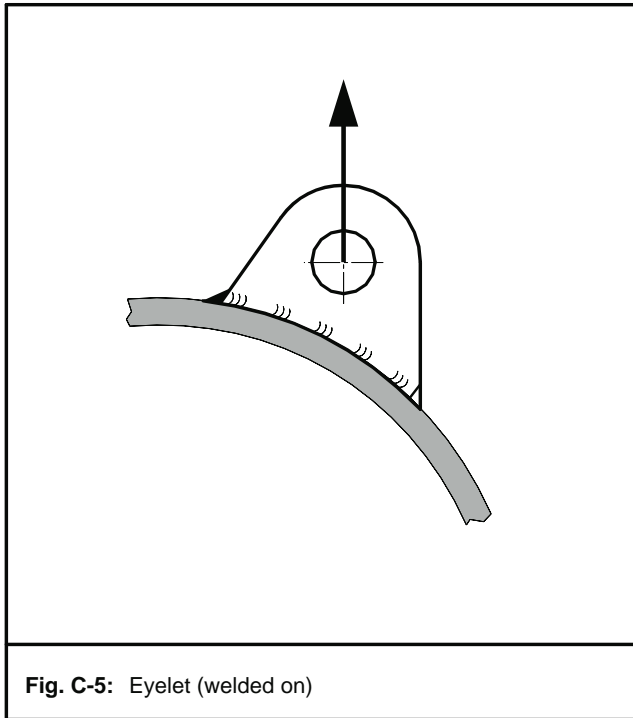

Note:

-  Load attaching point
-  Load



Note:

-  Load attaching point
-  Load

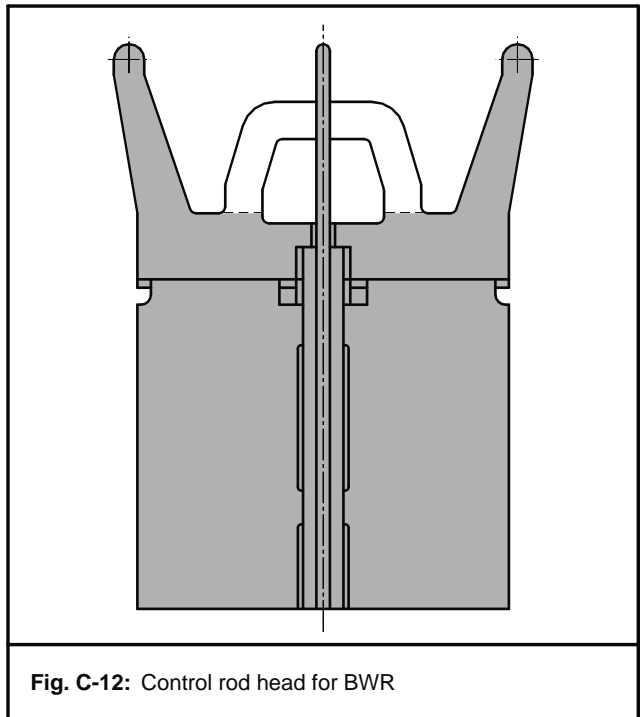
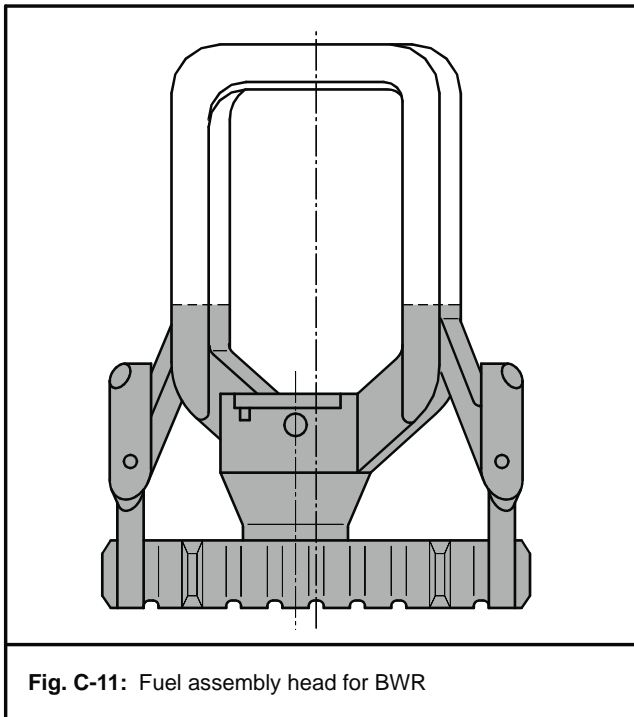
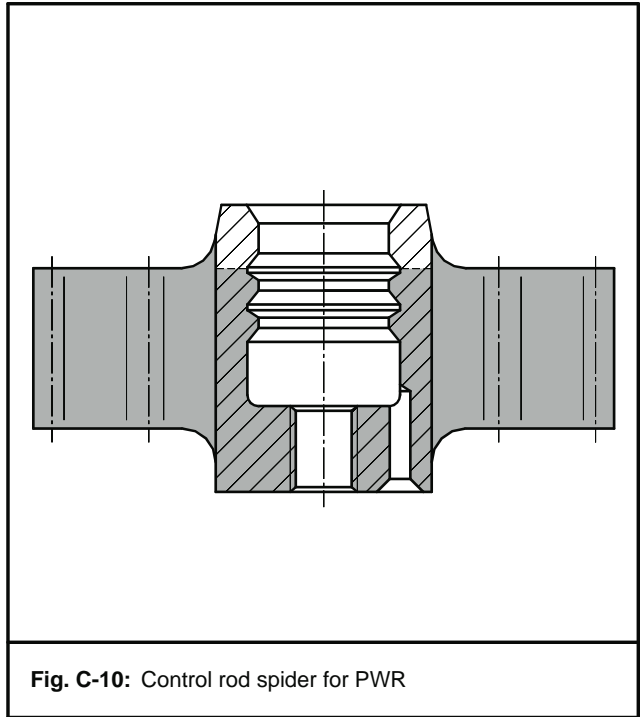
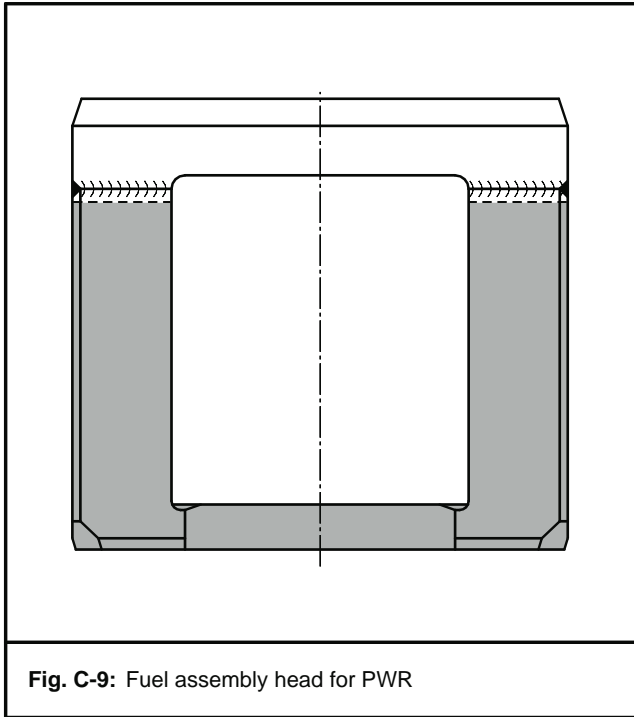

Annex D

Examples for the classification of load attaching points

No.	Component	Additional requirements in accordance with Section 4.2	Increased requirements in accordance with Section 4.3
1	Reactor pressure vessel cover		X
2	Stud tensioner for reactor pressure vessel cover bolts	X	
3	Sluice gate for separate cask pool, sluice gate between reactor well and setdown area as well as sluice gate between fuel element storage pool and setdown area		X
4	Horizontal slab over reactor well and setdown area		X
5	Spent fuel shipping cask		X

Table D-1: Examples for a PWR plant

No.	Component	Additional requirements in accordance with Section 4.2	Increased requirements in accordance with Section 4.3
1	Reactor pressure vessel cover		X
2	Stud tensioner for reactor pressure vessel cover bolts	X	
3	Shielding slab in reactor well		X
4	Sluice gate between fuel element storage pool and setdown pool		X
5	Shipping cask for irradiated fuel elements		X
6	Mobile auxiliary platform above the fuel element storage pool	X	
7	Container for radioactive waste, provided, it is handled in the storage pool area (e.g. mosaic and SAB-container)		X

Table D-2: Examples for a BWR plant

Annex E

Stress number diagrams for analysis of cyclic operation and endurance strength

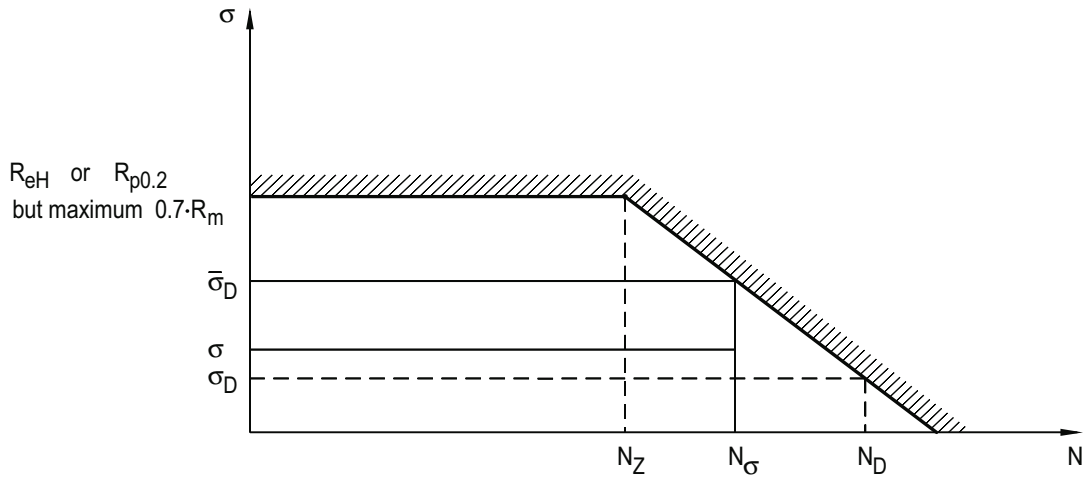

Figure E-1: S/N diagram for analysis of creep rupture strength ($N_\sigma < N_D$)

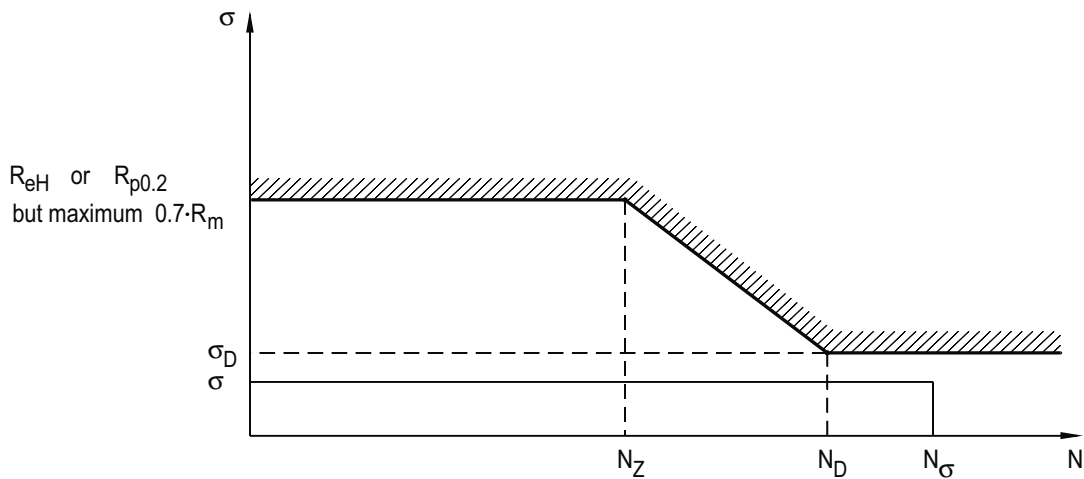

Figure E-2: S/N diagram for analysis of endurance strength ($\sigma < \sigma_D$ and $N_\sigma \geq N_D$)

Determination of the position of the S/N diagram

The position of the S/N diagram in the creep range which is represented as a straight line in a diagram with double logarithmic scale shall be determined by two pairs of values. Each pair of values shall be determined as follows:

- a) $N_D = 5 \cdot 10^6$ stress cycles and the endurance strength σ_D depending on the loading (compression, tension, bending).
The endurance strength applies to a survival probability of 50 %.

and

- b) $N_Z = 10^4$ stress cycles and the tensile strength or the yield point value limited to 0.7.
The governing parameter for specifying the yield point is the elastic ratio of the material used.

The following applies:

$$\frac{R_{eH} \text{ or } R_{p0.2}}{R_m} < 0.7 \quad \text{when using the yield point } R_{eH} \text{ or } R_{p0.2}$$

$$\frac{R_{eH} \text{ or } R_{p0.2}}{R_m} \geq 0.7 \quad \text{when using the tensile strength limited to } 0.7 \cdot R_m$$

Annex F

**Stress number diagrams for analysis of cyclic operation and endurance strength
of the materials 1.4541, 1.4306 and 1.4571 in accordance with DIN 17 440**

The stress number diagrams [6] shown in **Table F-1** and **Figures F-1** to **F-7** are permissible maximum stresses. They correspond to the stress collective S3 in the stress cycle ranges N1 to N4 (B4 to B6) in accordance with DIN 15 018-1.

The stress ratio R is 0 (cyclic tensile stress). In case of the pipe test specimen, R = -1 (alternating torsional stress).

The stress values for the notch case K4-R shall be shear stresses and for the other notch cases, normal stresses.

The allowable maximum stress may be determined by Haibach's equation:

$$\frac{S_{O,zul}}{S_D} = \left(\frac{N}{N_D} \right)^{-\frac{1}{k}}$$

The nomenclature for the above equation and for **Table F-1** is as follows:

$S_{O,zul}$ allowable maximum stress; synonymous symbol $\sigma_{O,zul}$

S_D stress coordinate of the break point of the S/N diagram; synonymous symbol σ_D

N number of stress cycles

N_D life coordinate of the break point of the S/N diagram

k inclination of the S/N diagram

K_t stress concentration factor; synonymous symbol α_K

Designation	Notch case ¹⁾	Stress ratio	Parameters of the S/N diagram in a double logarithmic coordinate system			Scope
			Stress coordinate of the break point	Life coordinate of the break point	Inclination	
		R	S_D , N/mm ²	N_D	k	
Perforated bar, $K_t = 2.4$	W 1-1 ²⁾	0	180.0	$1.81 \cdot 10^6$	6.96	$1.0 \cdot 10^5 < N \leq 1.81 \cdot 10^6$
Perforated bar, $K_t = 4.2$	W 1-2 ²⁾	0	104.3	$6.58 \cdot 10^6$	7.93	$1.0 \cdot 10^5 < N \leq 6.58 \cdot 10^6$
Butt joint	K 1	0	145.9	$2.20 \cdot 10^7$	12.98	$1.0 \cdot 10^5 < N \leq 1.00 \cdot 10^7$
Cruciform joint, double bevel butt joint, special quality	K 2 ²⁾	0	101.5	$5.58 \cdot 10^6$	6.19	$1.0 \cdot 10^5 < N \leq 5.58 \cdot 10^6$
Cruciform joint, double bevel butt joint, standard quality	K 3	0	88.8	$2.32 \cdot 10^7$	7.51	$1.0 \cdot 10^5 < N \leq 1.00 \cdot 10^7$
Cruciform joint, fillet weld	K 4	0	29.4	$1.01 \cdot 10^7$	3.91	$1.0 \cdot 10^5 < N \leq 1.00 \cdot 10^7$
Pipe test specimen, fillet weld	K 4-R ³⁾	-1	34.8	$1.32 \cdot 10^7$	3.84	$1.0 \cdot 10^5 < N \leq 1.00 \cdot 10^7$

¹⁾ Abbreviations based on DIN 15 018-1

²⁾ The following applies to the notch cases W 1-1, W 1-2 and K 2: $S_{O,zul} = S_D$ in the case of $N > N_D$

³⁾ The stress values for the notch case K 4-R are shear stresses

Table F-1: Values for the S/N diagrams in **Figures F-1** to **F-7**

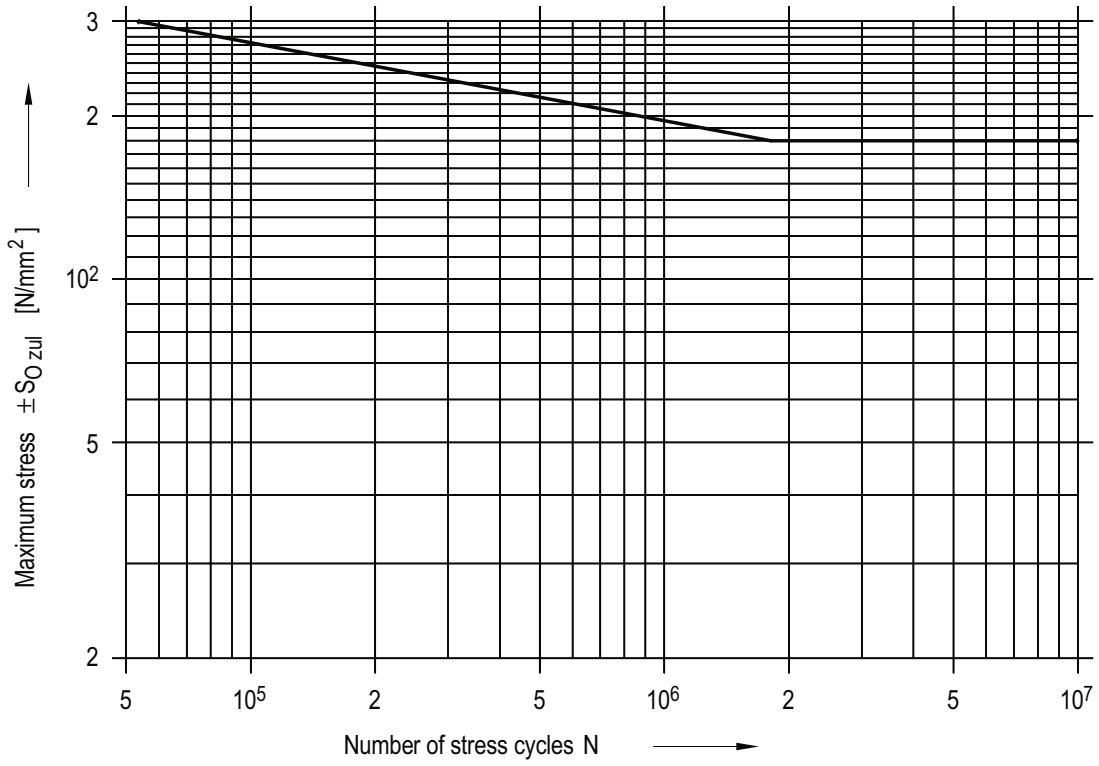

Figure F-1: S/N diagram for notch case W 1-1 (perforated bar, $K_t = 2.4$), $R = 0$

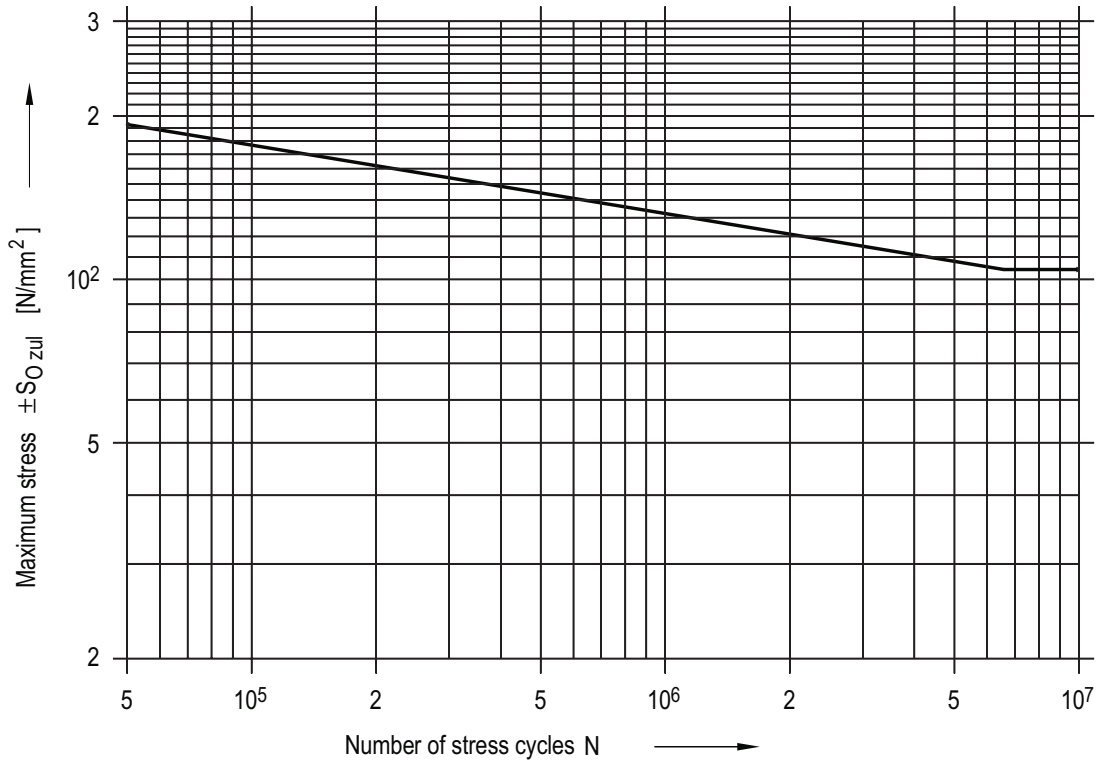

Figure F-2: S/N diagram for notch case W 1-2 (perforated bar, $K_t = 4.2$), $R = 0$

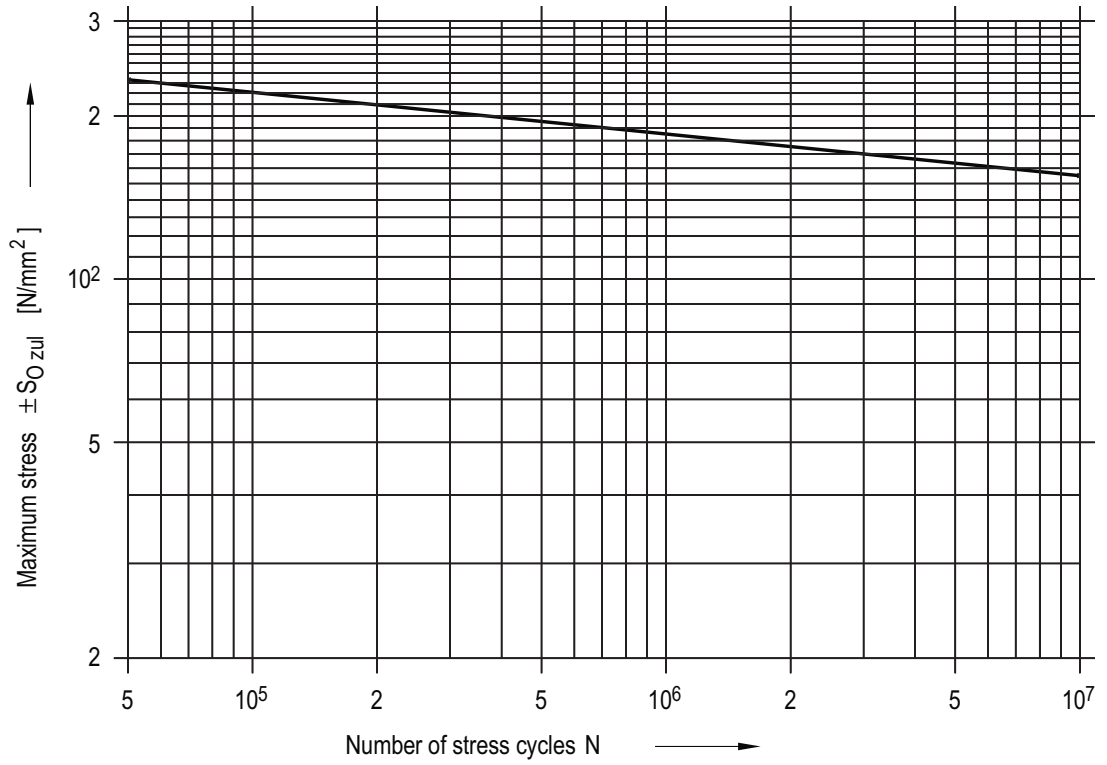

Figure F-3: S/N diagram for notch case K 1 (single-vee butt weld), R = 0

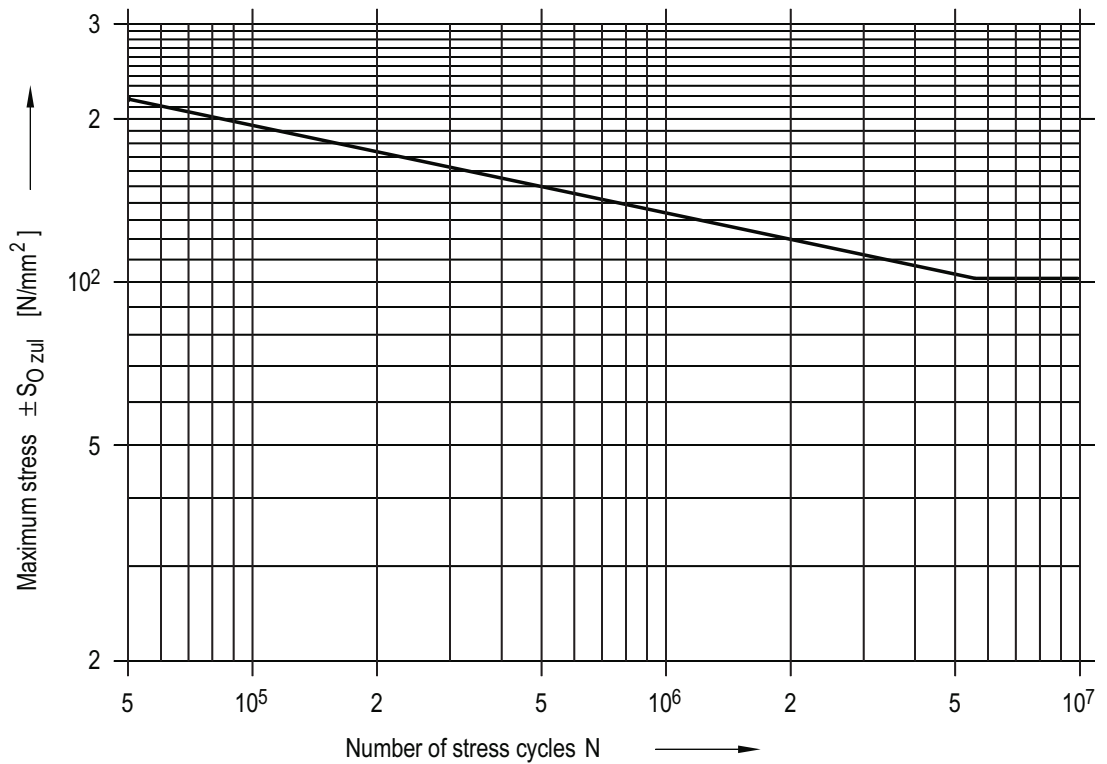

Figure F-4: S/N diagram for notch case K 2 (cruciform joint, double bevel butt weld, special quality), R = 0

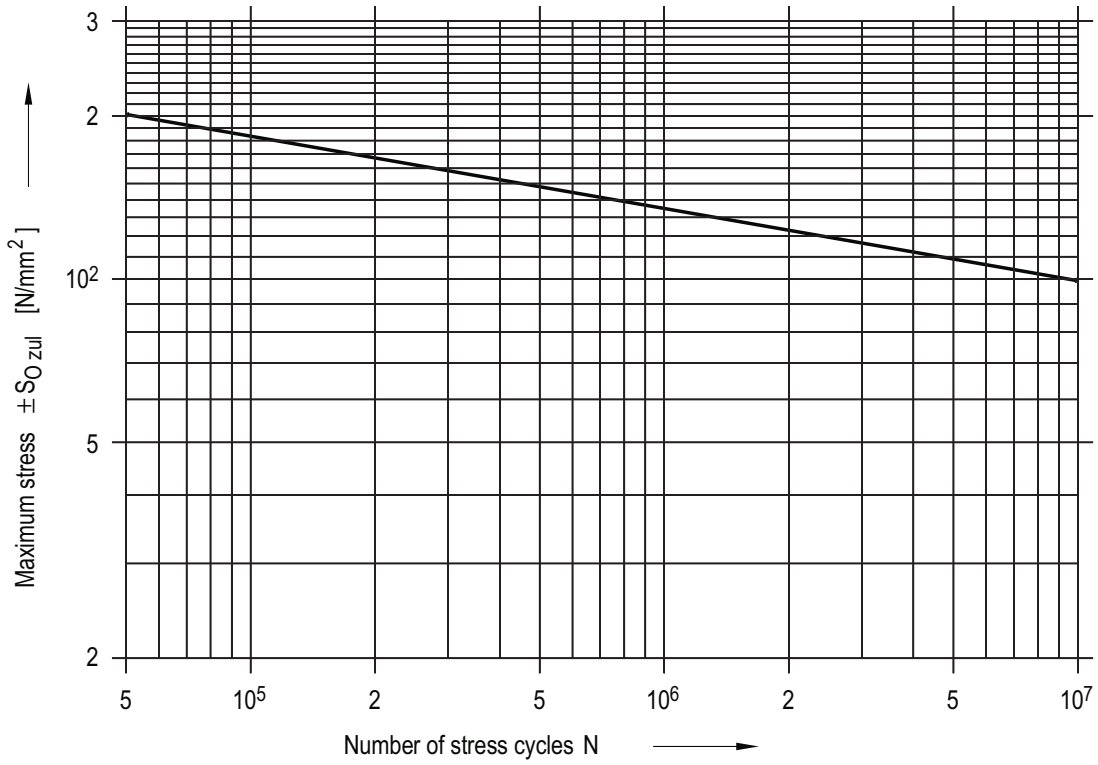

Figure F-5: S/N diagram for notch case K 3 (cruciform joint, double bevel butt weld, normal quality), R = 0

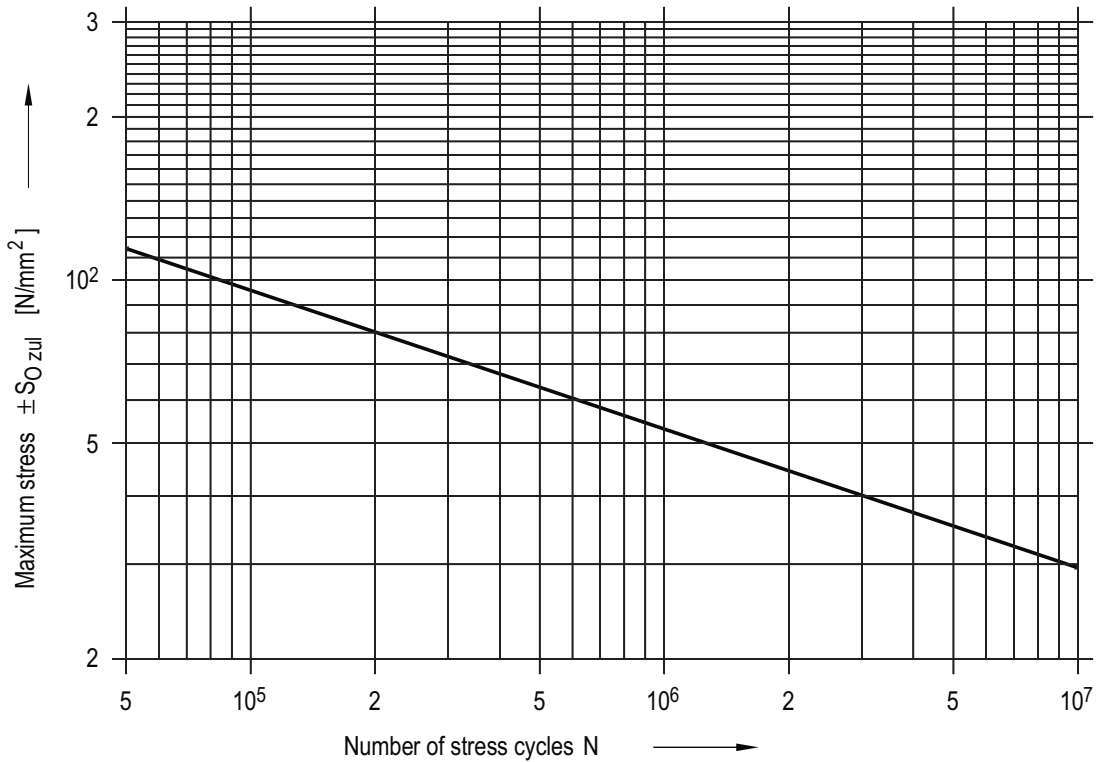

Figure F-6: S/N diagram for notch case K 4 (cruciform joint, fillet weld), R = 0

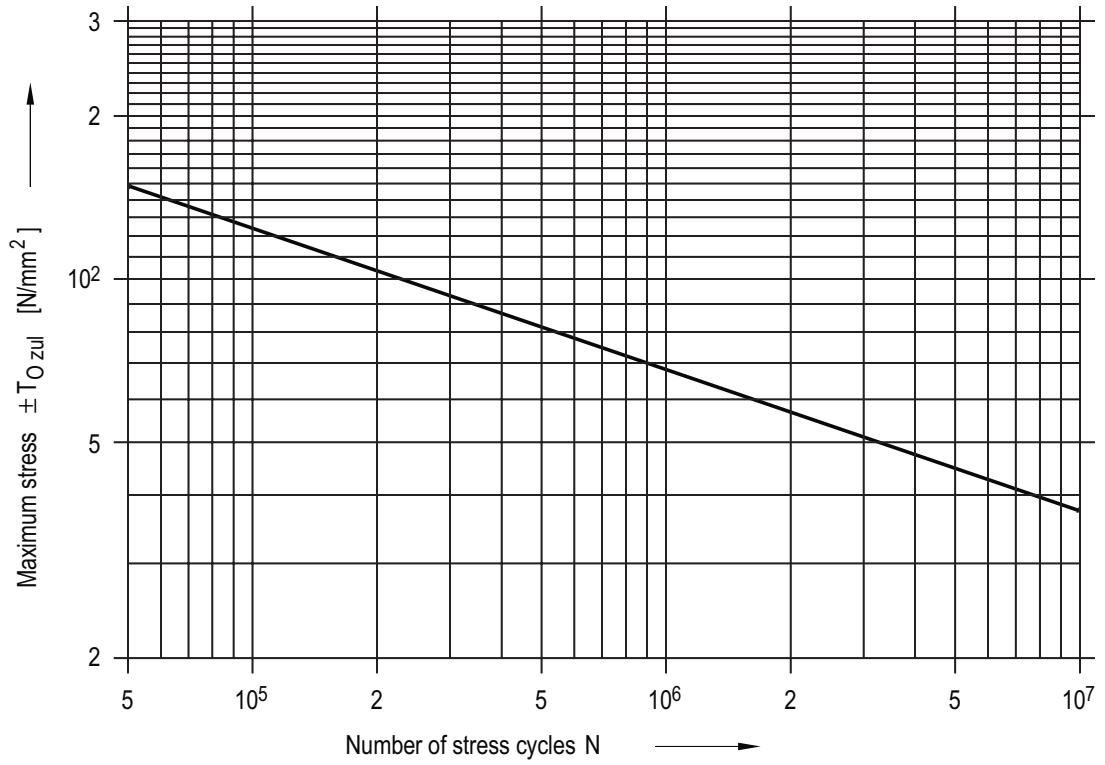

Figure F-7: S/N diagram for notch case K 4-R (pipe test specimen, fillet weld), $R = -1$

Annex G

Regulations and literature referred to in this Safety Standard

(The references exclusively refer to the version given in this annex. Quotations of regulations referred to therein refer to the version available when the individual reference below was established or issued.)

Atomic Energy Act (AtG)		Act on the Peaceful Utilization of Atomic Energy and the Protection against its Hazards (Atomic Energy Act) of December 23, 1959 (BGBl. I, p. 814) as Amended and Promulgated on July 15, 1985 (BGBl. I, p. 1565), last Amendment by the Act of April 6, 1998 (BGBl. I, p. 694)
KTA 1202	(06/84)	Requirements for the testing manual
KTA 1404	(06/89)	Documentation during the construction and operation of nuclear power plants
KTA 3201.3	(06/98)	Components of the reactor coolant pressure boundary of light water reactors; Part 3: manufacture
KTA 3201.4	(06/99)	Components of the reactor coolant pressure boundary of light water reactors; Part 4: In-service inspections and operational monitoring
KTA 3604	(06/83)	Storing, handling and on-site transportation of radioactive substances (other than fuel elements) in nuclear power plants
KTA 3902	(06/99)	Design lifting equipment in nuclear power plants
DIN 13-13	(10/83)	ISO metric screw threads; Selected sizes for screws, bolts and nuts from 1 to 52 mm screw thread diameter and limits of sizes
DIN EN 462-3	(11/96)	Non-destructive testing - Image quality of radiogrammes - Part 3: Image quality classes for ferrous metals; German version EN 462-3:1996
DIN 1045	(07/88)	Structural use of concrete; Design and construction
DIN 1055-1	(07/78)	Design loads for buildings; Stored materials, building materials and structural members, dead loads and angle of friction
DIN 1055-3	(06/71)	Design loads for buildings; Live loads
DIN EN 1435	(10/97)	Non-destructive examination of welds - Radiographic examination of welded joints; German version EN 1435:1997
DIN 1626	(10/84)	Welded circular unalloyed steel tubes subject to special requirements; Technical delivery conditions
DIN 1629	(10/84)	Seamless circular unalloyed steel tubes subject to special requirements; Technical delivery conditions
DIN 1690-2	(06/85)	Technical delivery conditions for castings made from metallic materials; Steel castings; Classification into severity levels on the basis of non-destructive testing
DIN 3088	(05/89)	Steel wire rope slings for lifting purposes; Safety requirements, marking and assembly
DIN ISO 3269	(12/92)	Fasteners; acceptance inspection; identical with ISO 3269:1988
DIN EN ISO 3506-1	(03/98)	Mechanical properties of corrosion-resistant stainless-steel fasteners. Part 1: Bolts, screws and studs (ISO 3506-1:1997); German version of EN ISO 3506-1:1997
DIN EN ISO 3506-2	(03/98)	Mechanical properties of corrosion-resistant stainless-steel fasteners. Part 2: Nuts (ISO 3506-2:1997); German version of EN ISO 3506-2:1997
DIN 4212	(01/86)	Reinforced concrete and prestressed concrete craneways; Design and construction
DIN EN ISO 4287	(10/98)	Geometrical product specification (GPS). Surface texture: Profile method. Terms, definitions and surface texture parameters. (ISO 4287:1997); German version of EN ISO 4287:1998
DIN 5688-3	(07/86)	Grade 8 chain slings with hook or ring type terminal fittings and endless slings
DIN EN 10 002-1	(04/91)	Tensile testing of metallic materials; Part 1: Method of test at ambient temperature; including amendment AC 1:1990; German version EN 10002-1:1990 and AC1:1990
DIN EN 10 025	(03/94)	Hot rolled products of non-alloy structural steels. Technical delivery conditions (incl. Amendment A1:1993); German version of EN 10025:1990
DIN EN 10 083-1	(10/96)	Quenched and tempered steels. Part 1: Technical delivery conditions for special steels; German version of EN 10083-1:1991
DIN EN 10 164	(08/93)	Steel products with improved deformation properties perpendicular to the surface of the product. Technical delivery conditions; German version of EN 10164:1993

DIN EN 10 204	(08/95)	Metallic products. Type of inspection documents (incl. Amendment A1:1995); German version of EN 10 204:1991 and A1:1995
DIN EN 10 210-1	(09/94)	Hot finished structural hollow sections of non-alloy and fine grain structural steels. Part 1: Technical delivery conditions; German version of EN 10210-1:1994
DIN 15 018-1	(11/84)	Cranes; Steel structures; Verification and analyses
DIN 15 018-2	(11/84)	Cranes; Steel structures; Principles of design and construction
DIN 17 100	(01/80)	General structural steels; Quality standard
DIN 17 103	(10/89)	Weldable fine grain structural steel forgings; Technical delivery conditions
DIN 17 240	(07/76)	Heat resisting and highly heat resisting materials for bolts and nuts; Quality specifications
DIN 17 440	(07/85)	Stainless steels; Technical delivery conditions for plate and sheet, hot-rolled strip, wire rod, drawn wire, steel bars, forgings and semi-finished products
DIN 17 445	(11/84)	Stainless steel castings; technical delivery conditions
DIN 17 457	(07/85)	Welded circular austenitic stainless steel tubes subject to special requirements; Technical delivery conditions
DIN 17 458	(07/85)	Seamless circular austenitic stainless steel tubes subject to special requirements; Technical delivery conditions
DIN 18 800-1	(03/81)	Steel structures; Design and construction
DIN 18 800-7	(05/83)	Steel structures; Fabrication, verification of suitability for welding
DIN EN 20 898-1	(04/92)	Mechanical properties of fasteners. Part 1: bolts, screws and studs (ISO 898-1:1981); German version of EN 20898-1:1991
DIN EN 20 898-2	(02/94)	Mechanical properties of fasteners. Part 2: nuts with specified proof load values; coarse thread (ISO 898-2:1992); German version of EN 20 898-2:1993
DIN EN 25 817	(09/92)	Arc-welded joints in steel; guidance on quality levels for imperfections (ISO 5817:1992); German version of EN 25817:1992
DIN EN 26 157-1	(12/91)	Fasteners; Surface discontinuities; Bolts, screws and studs subject to general requirements (ISO 6157-1:1988); German version EN 26157-1:1991
DIN EN 27 963	(06/92)	Welded joints in steel; calibration block No. 2 for ultrasonic examination of welds (ISO 7963:1985); German version of EN 27 963:1992
DIN 54 120	(07/73)	Non-destructive testing; calibration block 1 and its use for the adjustment and control of ultrasonic echo equipment
DIN 54 130	(04/74)	Non-destructive testing; magnetic leakage flux testing; general
DIN 54 152-1	(07/89)	Non-destructive testing; penetrant inspection; procedure
DIN 54 152-2	(07/89)	Non-destructive testing; penetrant inspection; verification of penetrant inspection materials
DAFStb	(03/81)	Guidelines for the dimensioning and design of composite steel girders
DAFStb	(03/84)	Supplementary regulations to the guidelines for the dimensioning and design of steel composite girders (issue of March 1981) Supplement: Dowels
DAFStb	(06/91)	Supplementary regulations to the guidelines for the dimensioning and design of steel composite girders (issue March 1981) Supplement: Crack formation
SEL 072	(12/77)	Ultrasonically tested heavy plate; Technical delivery conditions
SEP 1916	(12/89)	Non-destructive testing of fusion welded ferritic steel pipes
SEP 1917	(09/94)	Non-destructive testing of resistance welded pipes of ferritic steels
SEW 011	(08/84)	Physical characteristics of general structural steels in accordance with DIN 17 100 in the dimensional range > 100 mm and ≤ 250 mm
SEW 400	(02/91)	Stainless rolling and forging steels
SEW 550	(08/76)	Steels for larger forgings, quality regulations
VDI 2230 sheet 1	(07/86)	Systematic analysis of highly stressed bolted connections; Cylindrical single bolt connections
VdTÜV MB 1253/4		List of bolts, screws, studs, and nuts manufacturers (or processing firms) recognized by the German technical inspection agency (TÜV) <i>(the latest edition of this VdTÜV instruction sheet shall be used)</i>

ASTM B 352 - 92	Standard Specification for Zirconium and Zirconium Alloy Sheet, Strip, and Plate for Nuclear Application
ASTM E 8 - 96a	Standard Test Methods for Tension Testing of Metallic Materials
ASTM E 8 M - 96a	Standard Test Methods for Tension Testing of Metallic Materials [Metric]
ASTM E 21 - 92	Standard Test Methods for Elevated Temperature Tension Tests of Metallic Materials
ASTM G 2 - 88	Standard Test Methods for Corrosion Testing of Products of Zirconium, Hafnium, and Their Alloys in Water at 680 °F or in Steam at 750 °F

Literature

- [1] Niemann, G.
Maschinenelemente Band 1, Springer Verlag Berlin/Göttingen/Heidelberg 1981, 2. Auflage
(Machine Elements. Vol. 1, Springer Verlag, Berlin/Göttingen/Heidelberg 1981, 2nd edition)
- [2] Hähnchen, R.
Dauerfestigkeit für Stahl- und Gußeisen, Carl Hanser Verlag, München 1963
(Endurance Strength for Steel and Cast Iron, Carl Hanser Verlag, Munich 1963)
- [3] Decker, K.-H.
Maschinenelemente, Carl Hanser Verlag, München 1982
(Machine Elements, Carl Hanser Verlag, Munich 1982)
- [4] Hück, M.; Thraier, L; Schütz, W.
Berechnung von Wöhlerlinien für Bauteile aus Stahl, Stahlguß und Grauguß - Synthetische Wöhlerlinien - VdEh, Arbeitsgemeinschaft Betriebsfestigkeit, Bericht Nr. ABF 11, Düsseldorf, Juli 1983, 3. überarbeitete Fassung
(Calculation of S/N diagrams for Components made of Steel, Cast Steel and Grey Cast Iron - Synthetic S/N diagrams, VDEh, report No. ABF 11, Düsseldorf, July 1983; 3rd revised version)
- [5] Berechnungsgrundsätze für Hebezeuge, DIN-Fachbericht 1982
(Calculation Principles for Lifting Equipment, DIN technical report 1982)
- [6] Bork, C.-P., Hackbarth, A., Wohler, H.
Schwingfestigkeitsuntersuchungen an geschweißten Proben aus austenitischen Stählen im Hinblick auf Lastanschlagpunkte in Kernkraftwerken, Bundesanstalt für Materialforschung und -prüfung, Berlin, Januar 1993
(Endurance Strength Tests on Welded Test Specimens made of Austenitic Steels with Regard to Load Attaching Points in Nuclear Power Plants, Federal Institute for Material Research and Testing, Berlin, January 1993)

Annex H (informative)

Changes with respect to the edition 6/94 and explanations

(1) Section 1 "Scope" was extended to cover the load attaching points (LAP) on core components and encapsulations of core components. In the other sections additional requirements for LAP on core components were included in separate paragraphs. The former text of this safety standard was largely left unchanged and, where reasonably applicable, taken over in the new paragraphs on LAP on core components.

The encapsulation of core components means an enclosure of the core component. For the handling of the encapsulation including core component (e.g. for the loading of shipping/storage casks) the encapsulation contains one or more load attaching points. An encapsulation may contain one or several core components.

For LAP of the core components not mentioned in the scope no increased danger potential is to be expected due to the low dead weight and low frequency of handling of the components. Therefore, these LAP are designed, constructed, inspected and tested to the general rules of engineering practice.

Refuelling auxiliary equipment and test specimens are no core components.

Core components are:

In BWR facilities	in PWR facilities
fuel element	fuel element
fuel assembly channel	throttling device
control rod	control element
in-core instrumentation lance	in-core instrumentation lance
neutron source	neutron source
	absorber member

(2) The requirements to be met by LAP on RPV internals are contained in KTA safety standard 3204 "Reactor Pressure Vessel Internals" (06/98). For this reason, LAP on RPV internals are excluded from the scope.

(3) The question whether the classification of LAP on core components in accordance with Section 4.2 or 4.3 is reasonable, was discussed in detail. During the discussions it was found out that the level of requirements for LAP on core components with respect to the analysis and structural and mechanical design corresponds to the level obtained with a classification to Section 4.3. As a result of the discussions it was considered reasonable to lay down the requirements for LAP on core components irrespective of a classification in due consideration of the licencing procedures applied (analogously to the refuelling machines to KTA 3902).

(4) The requirements for a general stress analysis and the analysis for cyclic operation in Section 5 are based on a nominal stress concept. Where special strength analyses are made (e.g. finite element analyses), the stresses shall be evaluated to specific requirements in individual cases.

(5) In 5.1.1 "Design loads" new subpara (6) was included to consider transport loadings. Here, it was taken into account that each transport container acceptance is to be considered individually and the scope of KTA 3905 covers handling and transports within the nuclear plant (transports and handling outside the nuclear plant are subject to traffic legislation). Therefore, further provisions (e.g. to require acceleration values) were not possible and must be considered individually.

(6) Deviating from the requirements in KTA 3902, the value of $\psi = 1.8$ called live load factor in 5.2.2.1 (1), 5.3.2.1 (1), 5.4.2.1 (1) and 5.5.2.1 (1) represents a total coefficient resulting from the product of the live load factor to DIN 15 081-1, loading level 4, and the redundancy factor 1.25 ($\psi = 1.45 \times 1.25 \approx 1.8$). This simplification was selected since KTA 3905 exclusively considers non-redundant load attaching points.

(7) The requirements for the design, construction and analysis of core components are covered by Section 5.7. Here, it was taken into account that the requirements (e.g. in the case of welded joints) for LAP on core components have already been laid down in existing drawings and specifications and DIN 18 800-1 cannot be reasonably applied to core components. Therefore, changes in the procedure applied up to now which led to positive experience are avoided.

The load intensification factor $f_{ij} = 2.0$ covers the live load factor $\psi = 1.80$ required for increased requirements and the additional forces arising from frictional contacts.

The allowable stresses for primary membrane as well as primary membrane plus bending stress intensities were fixed in correspondence with the ASME Code, Section III, Subsection NG. The allowable stresses as used in KTA 3204 were also derived from Subsection NG.

Compared to the remaining application range of KTA 3905, for core components the primary membrane plus bending stress intensities are evaluated in addition to the primary membrane stress intensities (normal stresses), in which case for primary membrane stresses at least a safety factor of 1.5 against the yield point and for primary membrane plus bending stresses a safety factor of at least 1.5 against the formation of a plastic hinge (ideal elastic-plastic material behaviour) must be obtained. Due to the detailed consideration, for core components the stress analysis leads to the required safety factors which are at least equal to the safety factors required for LAP classified under Section 4.3 (increased requirements).

The stress intensities from the individual stress components are formed in accordance with the von Mises theory which leads to more applicable values than the Tresca theory.

The weld factor "v" to consider the type of loading and "v₂" to consider the weld quality shall be determined in accordance with NIEMANN (literature [1]).

The dimensioning of bolted joints is based on the applicable requirements of VDI 2230 sheet 1.

The experimental analyses for core components are made in correspondence with subsection NG of the ASME Code, Section III. For LAP on core components this procedure was taken over for the design against the rupture load L_U (or against the maximum test load). The design against the service load L_G (load for which limited plastic deformation is permitted, at which, however, the load suspension device may be detached from the LAP) was added. The verification is made with twice the weight of the load.

The method of verification using models as applied in Subsection NG of Section III, ASME Code, and in KTA 3204 was not taken over.

(8) The documents and certificates required for performing the design approval were adapted to the design of LAP on core components with respect to the design approval procedure used up to now. For this reason, specifications were also included on which the design, construction and analysis shall further be based. The specifications shall contain detailed requirements for welding procedures, fabrication, materials and tests and inspections to given test instructions.

(9) The extent of final inspection of LAP on core components were taken over as separate test object in Table 8-1. For core components the extent of test and inspections by the authorized inspector was limited to random checking because these LAP are integral parts of the components fabricated and inspected to qualified procedures. A partial test or inspection by the authorized inspector will suffice because the final inspection to Table 8-1 is not only limited to the supervision of the mere test steps, but also the effectiveness of the quality assurance system and the suitability of the fabrication processes as well as test and inspection procedures are checked and evaluated. In addition, the results of all tests and inspections are reviewed. The totality of these tests and inspections thus makes a total evaluation of all parts possible. This procedure corresponds to the practice experienced for many years with core components.

(10) A separate acceptance test is not required for LAP on core components since

- a) the component dimensions must be ensured for correct functioning and be checked within final inspection, and
- b) load tests are performed on LAP of BWR fuel elements within final inspection. For LAP on PWR fuel elements the load test may be omitted since the loads occurring do not reach the loading limits (oversizing since the functional requirements for the core component govern the dimensions).

(11) In-service inspections are not required for LAP on core components since the maximum number of cycles is low (e.g. approximately 20 for fuel elements) and a visual inspection is performed of the entire core component (e.g. in accordance with the requirements of test and inspection manuals).

(12) Annex A was adapted to the actual state of standardization and supplemented to contain requirements for LAP on core components. The references to DIN 17 100 (1/80) and SEW 11 (8/84) for forged bars and open-die forgings made of general structural steels, DIN 17 440 (7/85) and SEW 400 (2/91) referring to austenitic and stainless martensitic and austenitic-ferritic steels as well as DIN 54 152-1 (7/89) for the

performance of liquid penetrant testing were left unchanged although these standards were withdrawn in the meantime:

- DIN EN 10 025 (document replacing DIN 17 100) only applies to hot rolled products. Since for forged products no document is available, DIN 17 000 and SEW 011 must be referred to further.
- DIN 17 440 (7/85) has been replaced only in part by a European standard. It was considered necessary not to make any change until establishment of a European standard on forgings for general purposes and to further use DIN 17 440, edition 07/85 and SEW 400, edition 2/91 for all related product forms.
- At present, the application of DIN EN 571-1 (3/97) (document replacing DIN 54 152-1) is not possible until the requirements contained in other sections of DIN 54 152 regarding the reference blocks to be used, the testing of test fluids etc. have been replaced by a DIN EN standard with requirements compatible with DIN EN 571-1.

The materials test sheets WPB 17 "Plates made of zirconium alloys" and WPB 18 "Forged bars and open-die forgings made of weldable fine grain steels to DIN 17 103" were included as new sheets. Since no DIN standards exist for zirconium, the usual internationally accepted ASTM standards are used. For material identification marking, the manufacturer's mark and the stamping of the authorized inspector was renounced since it has not been usual up to now in fabrications nearly exclusively made in the USA.

(13) The stress number curves shown in Annex F for the analysis of cyclic operation of austenitic steels were determined by BAM (Federal Institute for Materials Testing) within the research program SR 0421 financed by BMU (Federal Ministry of Environment, Nature Conservation and Nuclear Safety). The tests were made on smooth, notched and welded specimens. Within the program SR 2258 (to be completed presumably at the end of 1999) the effect of mean stresses and the influence of the load collective will be investigated. It is intended to incorporate the results of this program in the next edition of KTA 3905.