

Safety Standards

of the
Nuclear Safety Standards Commission (KTA)

KTA 3404 (2008-11)

**Isolation of operating system pipes penetrating the
Containment Vessel in the case of a Release of
Radioactive Substances into the Containment Vessel**

(Abschließung der den Reaktorsicherheitsbehälter
durchdringenden Rohrleitungen von Betriebssystemen im
Falle einer Freisetzung von radioaktiven Stoffen
in den Reaktorsicherheitsbehälter)

A previous version of this Safety Standard
was issued 1988-09

If there is any doubt regarding the information contained in this translation, the German wording shall apply.

Editor:

KTA-Geschäftsstelle c/o Bundesamt fuer Strahlenschutz (BfS)
Willy-Brandt-Strasse 5 • D-38226 Salzgitter • Germany
Telephone +49-30-18-333-1621 • Telefax +49-30-18-333-1625

KTA SAFETY STANDARD

2008-11

Isolation of operating system pipes penetrating the Containment Vessel in the Case of a Release of Radioactive Substances into the Containment Vessel

KTA 3404

CONTENTS

Basic Principles	1
1 Scope	1
2 Definitions	2
3 Requirements	2
3.1 Penetration Isolation	2
3.2 Ventilation Isolation.....	2
3.3 Location of the Isolating valves	2
3.4 Types	2
3.5 Closure Time	3
3.6 Leaktightness.....	3
3.7 Initiation of the Isolating Function.....	3
3.8 Actuation.....	3
3.9 Indication and Interlocking	3
3.10 Supply of Auxiliary Media.....	3
3.11 Supply of Electric Power	4
3.12 Protection against Incident Consequences	4
3.13 Fuel Pool Cooling System.....	4
3.14 Inerting in a Boiling Water Reactor.....	4
4 Testing of Isolating Valves	4
4.1 General	4
4.2 Tests prior to Installation	4
4.3 Tests Following Installation.....	5
4.4 In-Service Inspections.....	5
4.5 Practice of the Authorized Expert under Sec. 20 of the Atomic Energy Act.....	5
4.6 Documentation.....	5
Appendix A Typical Examples of the Arrangement of Isolating Valves in Systems.....	6
Appendix B Regulations Referred to in this Safety Standard.....	9

PLEASE NOTE: Only the original German version of this safety standard represents the joint resolution of the 50-member Nuclear Safety Standards Commission (Kerntechnischer Ausschuss, KTA). The German version was made public in Bundesanzeiger No. 194a on October 14, 2000. Copies may be ordered through the Carl Heymanns Verlag KG, Luxemburger Str. 449, 50939 Koeln (Telefax +49-221-94373-603).

All questions regarding this English translation should please be directed to:

KTA-Geschaefsstelle c/o BfS, Willy-Brandt-Strasse 5, 38226 Salzgitter, Germany

Comments by the editor:

Taking into account the meaning and usage of auxiliary verbs in the German language, in this translation the following agreements are effective:

- shall** indicates a mandatory requirement,
- shall basically** is used in the case of mandatory requirements to which specific exceptions (and only those!) are permitted. It is a requirement of the KTA that these exceptions - other than those in the case of **shall normally** - are specified in the text of the safety standard,
- shall normally** indicates a requirement to which exceptions are allowed. However, the exceptions used, shall be substantiated during the licensing procedure,
- should** indicates a recommendation or an example of good practice,
- may** indicates an acceptable or permissible method within the scope of this safety standard.

Basic Principles

(1) The safety standards of the Nuclear Safety Standards Commission (KTA) have the task of specifying those safety related requirements which shall be met with regard to precautions to be taken in accordance with the state of science and technology against damage arising from the construction and operation of the facility (Sec. 7 para 2 subpara 3 Atomic Energy Act) in order to attain the protection goals specified in the Atomic Energy Act and the Radiological Protection Ordinance (StrlSchV) and which are further detailed in the "Safety Criteria for Nuclear Power Plants" and in the "Guidelines for the Assessment of the Design of PWR Nuclear Power Plants against Incidents pursuant to Sec. 28 para 3 of the Radiological Protection Ordinance (StrlSchV) - Incident Guidelines" (in the version published 18.10.1983).

(2) With respect to pipe penetrations, requirements are contained in Criterion 8.4, "Penetrations through the Containment Vessel", of the Safety Criteria for Nuclear Power Plants of October 21, 1977.

(3) The aim of this safety standard is the specification of the requirements for the isolation of the pipes of operating systems which penetrate the containment vessel, in order to avoid any inadmissible environmental impact if radioactivity is released into the containment vessel.

(4) For safety-related and operational reasons, a containment vessel to which the provisions of KTA safety standard series 3401 apply is provided with airlocks and pipe and cable penetrations. Requirements for personnel airlocks are specified in KTA 3402, for equipment airlocks in KTA 3409, and for cable penetrations in KTA 3403. Pipe penetrations are dealt with in KTA 3407.

(5) The pipes penetrating the containment vessel are either part of operating systems or part of safety systems. As the fuel pool cooling system has to fulfill not only operational functions, but also serves the long-term residual heat removal from the fuel pool, special aspects shall be taken into consideration. Special aspects also apply to the inerting in the case of boiling water reactors.

(6) The shutdown of the reactor and the removal of residual heat shall be ensured. Therefore, the pipes required for coping with incidents and thus belonging to the safety systems may not be isolated in all cases involving a release of radioactive substances into the containment vessel; thus, they are not dealt with in this safety standard. In as far as isolations of pipes are required in the respective systems, the specifications are contained in other KTA safety standards. As far as residual heat removal is concerned, reference is made to Sec. 5.4.3 of KTA 3301.

(7) Because of their possible connection to the environment, special requirements with respect to isolation (tightness, actuating time) shall be met by isolating valves of pipes which belong to operating systems and have an open connection with the containment vessel atmosphere. For pressurized water reactors, these requirements can be derived from the Incident Guidelines. In these Guidelines, the calculation of the radiological effects is based on a leak in the reactor coolant line which is twice the area of its cross section (2A). Furthermore, the incident referred to as "Fuel Assembly Damage during Handling" is investigated. With respect to this safety standard, analogous considerations apply to leaks in the main steam and feedwater pipes in the containment vessel of boiling water reactors.

(8) This safety standard deals with requirements for quantity, location, actuation, closing time and leak-tightness as well as testing of isolating valves for the isolation of pipes of operating systems which penetrate the containment vessel. Requirements for the design and testing of the associated electric

drives are contained in KTA 3504, requirements for the design and testing of the control features in KTA 3501.

(9) As far as the following specifications for number and arrangement of the isolating valves are concerned, it is assumed that a failure when operation is required need not be anticipated for the pipes between the containment vessel and the isolating valves and for the passive parts of the isolating valves. This is achieved by designing the pipe penetrations in accordance with KTA 3407 with respect to design, selection of materials, fabrication and testing.

(10) Requirements for pressure retaining parts of isolating valves are not contained in this safety standard. These are contained in KTA safety standard series 3201 and KTA 3211 and in KTA 3601.

(11) On the basis of the current state of design, a loss-of-coolant accident need not be postulated as a causal consequence of an earthquake or any other external impact. Therefore, this safety standard does not contain any requirements for the design of the isolating valves discussed here with regard to earthquakes.

1 Scope

(1) This safety standard applies to the isolation of the pipes of operating systems which penetrate the containment vessel, including the associated instrumentation pipes and the fuel pool cooling system, in stationary nuclear power plants with light water reactors.

Note:

The operating systems include systems which convey reactor coolant or operation-related auxiliary media during specified normal operation, systems which have an open connection to the containment vessel atmosphere, and systems which constitute closed systems inside and outside the containment vessel. Examples for the pressurized water reactor are:

- (a) volume control system,
- (b) nuclear sampling system,
- (c) ventilation and air filtration system,
- (d) nuclear closed cooling system for operational cooling locations,
- (e) fuel pool purification system,
- (f) nuclear component drain system,
- (g) demineralized water system,
- (h) steam generator blowdown system,
- (i) conventional sampling system,
- (k) gas supply system.

Examples for the boiling water reactor are:

- (a) seal water system,
- (b) reactor coolant pump oil supply system,
- (c) auxiliary steam pipe,
- (d) coolant extraction and return system,
- (e) nuclear component drain system,
- (f) demineralized water supply system,
- (g) main steam system,
- (h) main feedwater system,
- (i) nuclear sampling system,
- (k) ventilation and air filtration systems,
- (l) gland leakoff system.

(2) This safety standard shall not be applied to the isolation of the pipes of safety systems which penetrate the containment vessel. The safety systems include all systems penetrating the containment vessel which serve the shutdown, emergency cooling, residual heat removal, assurance of long-term subcriticality, prevention of inadmissible activity releases to the environment as well as compliance with the mechanical and thermal design conditions of the containment vessel during and after incidents.

(3) The requirements concern the number, arrangement, activation, actuating time and tightness as well as the testing of isolating valves for the isolation of pipes of operating systems. Requirements for the design and testing of the associated electric drives are contained in KTA 3504, requirements for the design and testing of the control features in KTA 3501.

2 Definitions

(1) Penetration isolation

The penetration isolation is the closing of all isolating valves of the pipes of operating systems which penetrate the containment vessel.

(2) Ventilation isolation

The ventilation isolation as part of the penetration isolation is the closing of the isolating valves of pipes of ventilation systems which penetrate the containment vessel.

(3) Indirectly acting isolating valves

Indirectly acting isolating valves are valves which must be activated and are provided with closing energy in the form of external energy or external media or closing energy from the medium to be isolated (own medium).

(4) Directly acting isolating valves

Directly acting isolating valves are valves which close automatically as a result of changes of a variable of state of the medium to be isolated and which are provided with closing energy from the medium to be isolated.

(5) Closure time

The closure time is the time which an isolating valve needs from the arrival of an actuation signal at the isolating valve until the achievement of the defined closing position.

(6) Emergency power supply

Emergency power supply is the supply of power of emergency power consumers from the emergency power facility.

3 Requirements

3.1 Penetration Isolation

(1) Following the occurrence of a loss-of-coolant accident, the respective penetrations shall be isolated, taking into consideration the loads acting in this context. The closed state of the isolating valves shall be maintained as long as this is necessary for reasons of safety.

Note:

The penetrations have already been isolated in the case of isolating valves of operating systems which are closed and locked in the closed state in such a way that they can only be opened if the primary circuit is in a depressurized state.

(2) Requirements for the isolation of the fuel pool cooling system are contained in Section 3.13.

3.2 Ventilation Isolation

In the case of a release of radioactive substances into the containment vessel which leads to the annunciations specified in Section 3.7.2, the ventilation penetrations shall be isolated. The closed state of the isolating valves shall be maintained as long as this is necessary for reasons of safety.

3.3 Location of the Isolating valves

(1) When specifying the number and arrangement of the isolating valves in the pipes which penetrate the containment vessel, a distinction shall be made between isolating valves of:

- (a) pipes conveying reactor coolant,
- (b) pipes which have an open connection to the containment vessel atmosphere and are used for air supply and venting purposes during power operation,
- (c) pipes which have an open connection to the containment vessel atmosphere and are used for air supply and ventilation purposes during a reduced pressure in the primary circuit,
- (d) pipes which have an open connection to the containment vessel atmosphere and are used for the operational monitoring of the containment vessel atmosphere; for this purpose, only pipes having a nominal diameter smaller than DN 50 shall be used,
- (e) pipes which neither convey reactor coolant nor have an open connection to the containment vessel atmosphere.

Note:

Piping which has an open connection to the containment vessel atmosphere is understood to be those lines which directly connect the atmospheres inside and outside the containment vessel.

(2) Isolating valves in accordance with paragraph (1) items (a) through (d) shall be arranged in duplicate and in series, one on the inside and one on the outside, each as close to the containment vessel as possible. Exceptions concerning this arrangement are admissible if this is necessary because of the design characteristics of the isolating valves, or the mode of operation of the pipes concerned, and assurance of the penetration or ventilation isolation is not affected.

(3) Instrumentation pipes for operating purposes having a nominal diameter smaller than or equal to DN 15 in accordance with paragraph (1) items (a), (d) and (e) which penetrate the containment vessel and end in a permanently installed transducer need not be isolated if the instrumentation pipes and the associated transducer are designed, constructed and arranged in such a way that their failure need not be taken into consideration in the event that radioactive substances are released inside the containment vessel.

(4) Isolating valves in accordance with paragraph (1) item (e) shall be arranged as single valves outside the containment vessel if the pipes outside the containment vessel are designed to withstand the design pressure of the containment vessel and convey pressurized fluids during normal operation.

(5) Isolating valves in accordance with paragraph (1) item (e) shall be provided in a dual valve arrangement in series outside the containment vessel, or else one outside and one inside the containment vessel, if the pipes outside the containment vessel behind the isolating valves are not designed to withstand the design pressure of the containment vessel or, do not carry pressurized fluids outside the containment vessel during normal operation.

3.4 Types

(1) Directly or indirectly acting isolating valves shall be provided for the isolation of the pipes. If, in the case of directly acting isolating valves (see Section 2, Definition 4), it is not ensured that they move into and remain in the isolating position, an additional device shall be provided to move them into and keep them in the isolating position.

(2) Per demand water conveying systems having a temperature lower than the maximum loss-of-coolant accident temperature in the containment vessel, a heating-up of the en-

closed water can not be ruled out. The pressure buildup resulting between the isolating valves shall be limited.

Note:

Further details are contained in KTA 3407.

(3) Isolating valves in accordance with Section 3.3 (1) items (b) and (c) may be equipped with similar or different drives (e.g. spring, dead weight, drop weight). These isolating valves shall move automatically into the isolating position both if the supply of auxiliary media and if the supply of power fails. These isolating valves shall be provided with double seals and an extraction capability.

3.5 Closure Time

(1) The maximum allowable closure time of the isolating valves shall be determined on the basis of the radiological impact on the environment resulting from the incident analysis, and in such a way that the release to the environment through the pipes penetrating the containment vessel which occurs until the penetration and ventilation isolations have been affected is small as compared with the total release to the environment caused by an incident.

(2) This demonstration is not required in the case of compliance with the following closure times which event tree analyses have shown to be conservative:

- (a) 60 seconds for isolating valves in accordance with Section 3.3 (1) items (a) and (e),
- (b) smaller than or equal to 3 seconds for isolating valves in accordance with Section 3.3 (1) item (b);
- (c) smaller than or equal to 10 seconds for isolating valves in accordance with Section 3.3 (1) item (c),
- (d) smaller than or equal to 30 seconds for isolating valves in accordance with Section 3.3 (1) item (d).

3.6 Leaktightness

(1) Isolating valves shall be sufficiently leaktight. This requirement is deemed to have been met if, in the integrated leak rate test of the containment vessel, the upper confidence limit of the measured leak rate in accordance with KTA 3405 is not greater than the admissible leak rate of the containment vessel.

Note:

The results of integrated leak rate tests which have been performed show that the leaktightness requirements to be met by the entire system are complied with if the isolating valves are constructed in accordance with the requirements of the manufacturing test. Therefore, with a view to the integrated leak rate of the containment vessel, no quantitative leak tightness requirements are specified for individual isolating valves. Since it is mainly the pipes of a nominal diameter of \geq DN 50 and with an open connection to the containment vessel atmosphere that are important with respect to the release of radioactivity to the environment, (isolating valves in accordance with Section 3.3 (1) items (b) and (c)), the requirement in paragraph (2) applies to these.

(2) With respect to isolating valves in accordance with Section 3.3 (1) items (b) and (c), the leaktightness requirements shall be specified in a component-related manner. Leaktightness shall be demonstrated either by a vacuum test method or a pressure decay method.

Note:

Component-related specifications are contained in KTA 3601.

3.7 Initiation of the Isolating Function

3.7.1 In the Case of Loss-of-Coolant Accidents

In the case of loss-of-coolant accidents, the isolation of the penetration shall be initiated via the reactor protection system.

Note:

In the case of loss-of-coolant accidents which require the immediate isolation of all penetrations of the operating system, the isolation is initiated automatically by actuations which are faster than an activity measurement in indicating the necessity of the isolation. For this purpose, changes of variables of state are used such as system pressure, level, or pressure in the containment vessel.

3.7.2 In the Case of a Release of Radioactive Substances

(1) In the case of a release of radioactive substances into the containment vessel, for example during fuel handling in a pressurized water reactor or as a result of leakages, the isolation of the ventilation systems shall be initiated even if the response limits for the initiation of the penetration isolations are not reached.

(2) Depending on the results of incident analyses and on the radiation exposures to be expected in the environment, the ventilation isolation shall be initiated either manually in the control room or automatically as soon as suitable variables of state exceed limit values. Examples of suitable variables of state are:

- (a) radioactivity in the vent air of the containment vessel,
- (b) radioactivity above the fuel pool.

3.8 Actuation

(1) All indirectly acting isolating valves which serve the isolation of penetrations shall be capable of being actuated

- (a) by the reactor protection system, with priority over operating signals (see KTA 3501),
- (b) by simulated reactor protection initiation signals for testing purposes as a result of the requirements in terms of operation or systems engineering, either individually or in groups,
- (c) manually from the control room.

(2) This shall also apply to additional equipment for moving indirectly acting isolating valves in accordance with Section 3.4 (1) into the isolating position and for keeping them in this position.

3.9 Indication and Interlocking

(1) All indirectly acting isolating valves of operating systems and all additional equipment required to achieve and maintain a leaktight position in the isolation valves in accordance with Section 3.4 (1) which are actuated by the transported media shall indicate their respective positions in the control room.

(2) The ultimate position reached on demand by all the isolating valves falling under the scope of this safety standard shall be indicated in the control room.

(3) For isolating valves of pipes in accordance with Section 3.3 (1) item (c), an interlock shall ensure that these isolating valves can only be opened during a reduced primary pressure.

3.10 Supply of Auxiliary Media

If auxiliary media are required by isolating valves arranged in series in order to effect the closing process, a supply of auxiliary media is required which media shall be independent of each other (for example, one accumulator for each isolating valve). If, in the case of a failure of the auxiliary media supply, the isolating valves move automatically into and remain in the closed position, this requirement is waived.

3.11 Supply of Electric Power

(1) Electric drives for the closing of isolating valves shall be connected to the emergency power supply system.

(2) Electric drives for the closing of isolating valves connected in series shall be connected to different redundancies of the emergency power supply system.

3.12 Protection against Incident Consequences

Isolating valves, pipes for the supply with auxiliary media and electric power supply cables which are required for the closing function of the isolating valves shall be protected or designed against the consequences of incidents, such as they may be caused by escaping media, reaction forces and missiles.

Note:

The requirements for pipe sections between the containment vessel and the isolating valves are dealt with in KTA 3407.

3.13 Fuel Pool Cooling System

(1) Pipes of the fuel pool cooling system which penetrate the containment vessel shall be provided with one isolating valve each outside the containment vessel.

(2) If the fuel pool cooling system is designed to withstand the design pressure of the containment vessel, the isolating valves need not be included in the penetration isolation in order to avoid any interruption of heat removal.

Note:

The requirements for heat removal systems of water-cooled fuel pools in the reactor building of LWR nuclear power plants are dealt with in KTA 3303.

3.14 Inerting in a Boiling Water Reactor

(1) In principle, the isolating valves of pipes for inerting in boiling water reactors are closed during power operation; they are only opened either on a short-term basis or if certain if certain plant conditions exist. Therefore, in deviation from and as a supplement to the specifications of sections 3.1 through 3.13 and of Section 4, the following specifications shall apply to the isolating valves of pipes which serve the inerting or de-inerting of the containment vessel and penetrate the containment vessel:

Isolating Valve	1	2	3
Mode of Operation	Basically closed. Open only for inerting	Basically closed. Open only for inerting	Closed during power operation. Open only when priority pressure decreased
Nominal Diameter	≤ 80	> 80 to 250	> 80
Interlocking	no	no	Section 3.9 (3)
Closing Time	≤ 30 s	≤ 10 s	≤ 10 s

If the required closing times cannot be attained with electric drives, the requirements of Section 3.4 (3) and section 4.2 shall apply.

(2) The following specifications shall apply to the tests after installation and the in-service inspections - irrespective of the limitation to isolating valves in accordance with Section 3.3 (1) items (b) and (c):

Isolating Valve	1	2	3
Tests after Installation	Section 4.3 (1)	Section 4.3	Section 4.3
In-Service Inspections			
(a) Function	every 3 months	every 3 months	prior to every starting of the system
(b) Closing Time	at each refueling operation	at each refueling operation	at each refueling operation
(c) Leak-tightness	Section 3.6 (1)	Section 3.6 (1) at each refueling operation	Section 3.6 (1) at each refueling operation

If, due to the particular design, a component related leak tightness test in accordance with Section 3.6 (2) (for example, double seal) cannot be carried out, an extraction capability shall be provided between the two isolating valves which can be used to test the tightness of the valves.

4 Testing of Isolating Valves

4.1 General

By means of tests of the operability in accordance with DIN 31 051 and of the closing time, the isolating valves shall be demonstrated to close reliably. The design prerequisites for the feasibility of these tests shall be specified in the production documents of the isolating valves.

4.2 Tests prior to Installation

4.2.1 General Requirements

(1) For isolating valves in accordance with Section 3.3 (1) item (b) which are used for the air supply to and venting of the containment vessel, tests in accordance with Sections 4.2.2 through 4.2.5 shall be carried out.

(2) These tests shall be carried out in a test facility once for each type, design and nominal width. In as far as this appears to make sense, the tests may be combined with each other, i.e. the leak tightness tests may be performed in the end positions of the isolating valves in the course of the serviceability test.

4.2.2 Serviceability Test to Demonstrate Functionability and Reliability of the Isolating Valves

(1) The following shall be carried out as serviceability tests for isolating valves without volumetric flow:

- (a) 50 000 cycles for nominal pipe diameter ≤ DN 150,
- (b) 20 000 cycles for nominal pipe diameter > DN 150.

(2) The test shall cover all the constituents of the isolating valves which determine operability and tightness. For electric drives and actuating magnets, suitability shall be demonstrated. The serviceability test shall be carried out at different testing temperatures for different numbers of cycles. Testing temperature and percentage of cycles are contained in **Table 4-1**.

Note:

The requirements for the proof of the suitability of electric drives are dealt with in KTA 3504.

Percentage of cycles required	Testing temperature
9 %	273 K
60 %	Ambient temperature at place of use (293 K to 313 K)
30 %	363 K
1%	Design temperature of the containment vessel

Table 4-1: Allocation of Cycles and Testing Temperature

(3) Leaktightness tests in accordance with the requirements of Section 3.6 (2) shall be carried out before and after each change of testing temperature. The leak tightness tests shall be carried out with open housings at inlet and outlet.

Note:

If failures of seals occur during the serviceability test, this means, as a matter of principle, that the serviceability test has not been passed. Depending on the result of the test, time intervals for an exchange of these seals may be specified.

4.2.3 Test of operability at Flow Conditions such as they are Representative for the Design Basis Case

Operability of the isolating valves shall be tested and demonstrated by five closing processes at the inflow velocity which is representative for a loss-of-coolant accident. For this purpose, no admission of temperature or moisture is required. A leak-tightness test shall be carried out subsequently.

4.2.4 Test of the Seals under Incident Conditions (Pressure and Temperature after Loss-of-Coolant Accident)

(1) The operability of the seals of the isolating valves after an incident shall be demonstrated by a suitable test under incident conditions. For this purpose, the seal shall be exposed for at least 10 hours to the maximum loss-of-coolant accident temperature that will occur. Subsequently, the leak-tightness shall be tested at maximum loss-of-coolant accident pressure and at both loss-of-coolant accident temperature and ambient temperature at the location of use in accordance with the requirements of Section 3.6 (2).

(2) Depending on the time of use and the ambient conditions at the location of use, prior thermal, mechanical and radiation-related prestressing shall be taken into consideration when testing non-metallic seals.

4.2.5 Visual Inspection

Following the serviceability test, the seals shall be inspected visually for wear.

4.3 Tests Following Installation

(1) Prior to nuclear commissioning, the following shall be demonstrated for each isolating valve in accordance with Section 3.3 (1):

- (a) operability by means of initiation through simulated reactor protection initiation signals, and
- (b) compliance with the required closing time.

(2) Prior to nuclear commissioning, the following shall be demonstrated in addition for each isolating valve in accordance with Section 3.3 (1) items (b) and (c):

- (a) leaktightness with a test method in accordance with Section 3.6, and
- (b) operability of the interlocking device in the case of isolating valves the closed position of which is secured by interlocks.

4.4 In-Service Inspections

(1) The in-service inspections shall be carried out as indicated in **Table 4-2**.

(2) If the interval between two refueling operations is longer than 18 months, the inspections shall be performed after 21 months at the latest.

(3) If the closed position of the isolating valves is secured by interlocks, the Interlocking devices shall also be tested at the time the operability of the valves is tested.

Isolating Valves in Accordance with Section 3.3 (1)	Time of Testing of		
	Operability	Closing Time	Leak-tightness
item (a)	at each refueling	at each refueling	--
item (b)	every 3 months	every 6 months	at each refueling
item (c)	prior to each start of the system	at each refueling	at each refueling
item (d)	every 3 months	at each refueling	--
item (e)	at each refueling	et each second refueling	--

Table 4-2: Times of in-service inspections for isolating valves in accordance with Section 3.3 (1) items (a) through (e)

4.5 Practice of the Authorized Expert under Sec. 20 of the Atomic Energy Act

(1) The involvement of the authorized expert in tests in accordance with Section 4.2 shall be laid down in the test specifications.

(2) The participation of the authorized expert is required for tests in accordance with Section 4.3 and Section 4.4 which have to be carried out for refueling. The participation of the authorized expert in tests of the operability and closing time of the isolating valves in accordance with Section 3.3 (1) item (b) is required every 12 months.

(3) The proper performance of these tests and the recording of the test results shall be confirmed by the authorized expert.

4.6 Documentation

The results of the tests in accordance with Sections 4.2 through 4.4 shall be documented in a test proof stating the testing method employed. The test proof shall contain the data, variables of state, specified data and actual data which are characteristic of the testing, process.

Appendix A

Typical Examples of the Arrangement of Isolating Valves in Systems

The data relating to the isolating valves in the various figures do not claim to be complete. They are intended to illustrate the arrangement of the isolating valves specified in Section 3.3 and to provide further information (for example, nominal diameter). The examples quoted refer to a convoy plant (pressurized water reactor) and Units B and C of Gundremmingen Nuclear Power Plant (boiling water reactor), with the exception of Figs. A-10 and A-11.

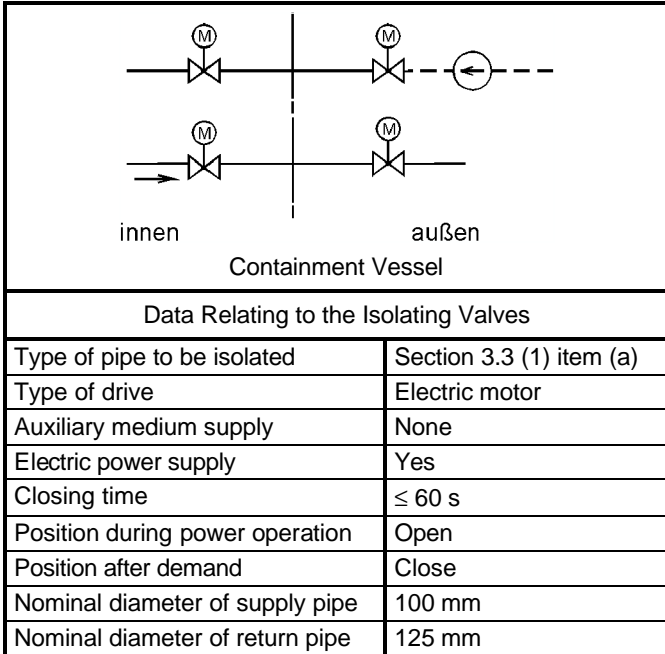

Fig. A-1: Example of an arrangement of isolating valves for the volume control system of pressurized water reactors

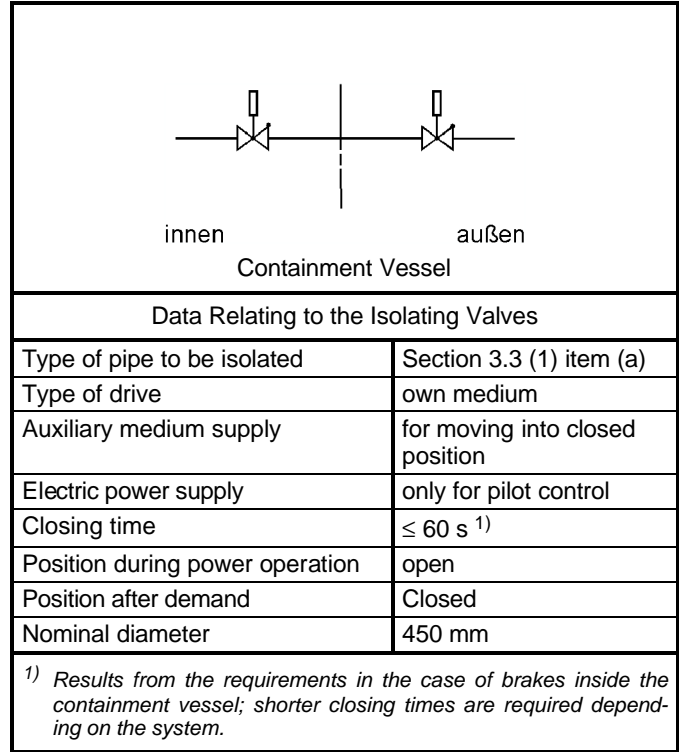

Fig. A-3: Example of an arrangement of isolating valves for the main feedwater system of boiling water reactors

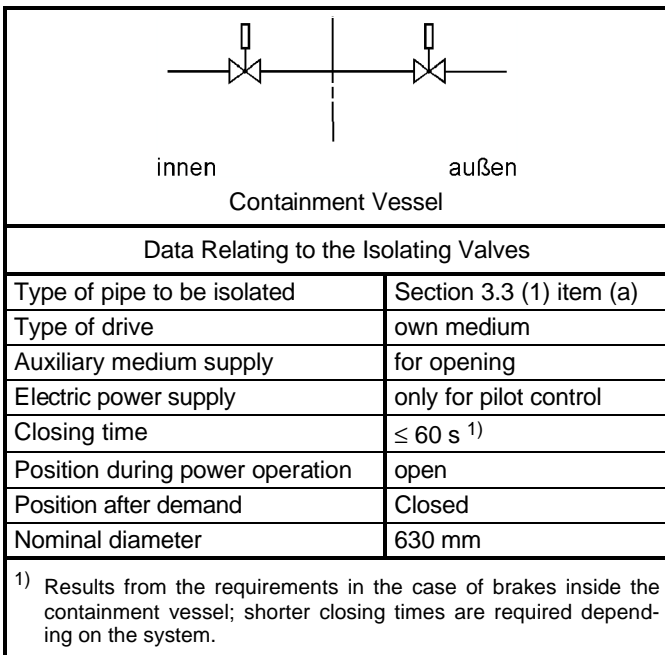

Fig. A-2: Example of an arrangement of isolating valves for the main steam system of boiling water reactors

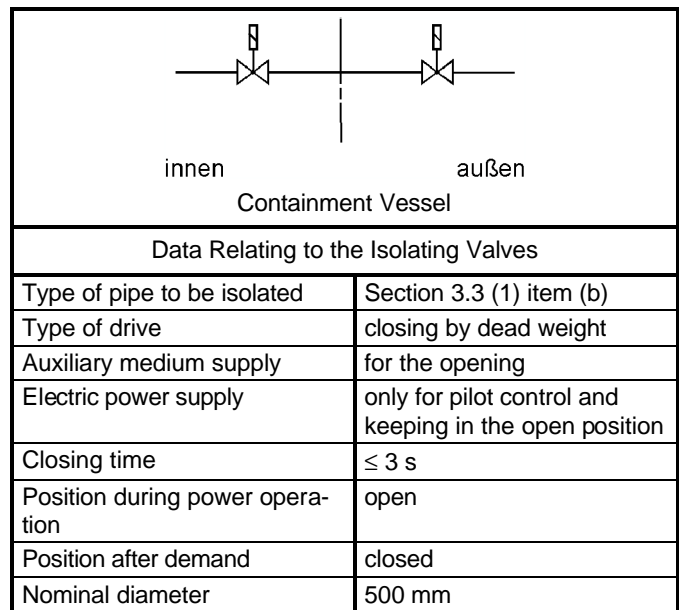

Fig. A-4: Example of an arrangement of isolating valves for the ventilation system (maintenance of subatmospheric pressure) of pressurized water reactors

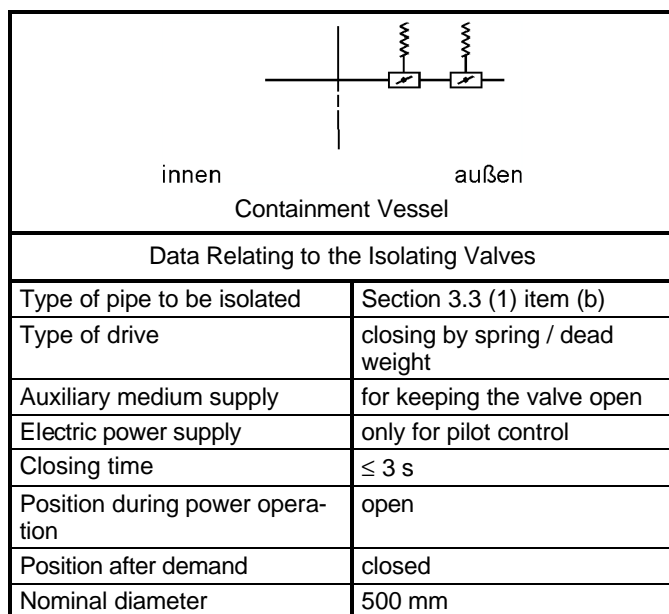

Fig. A-5: Example of an arrangement of isolating valves for the ventilation system of boiling water reactors

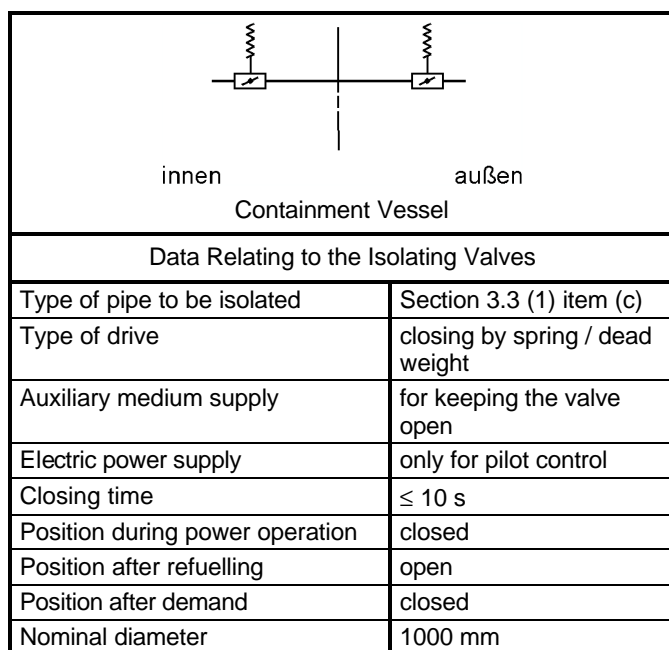

Fig. A-6: Example of an arrangement of isolating valves for the ventilation system (flushing of the containment vessel) of pressurized water reactors.

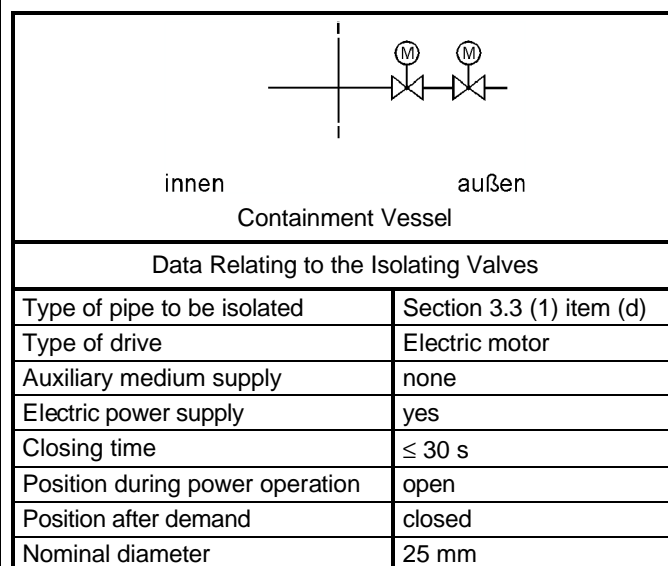

Fig. A-7: Example of an arrangement of isolating valves for the activity monitoring system of pressurized water reactors

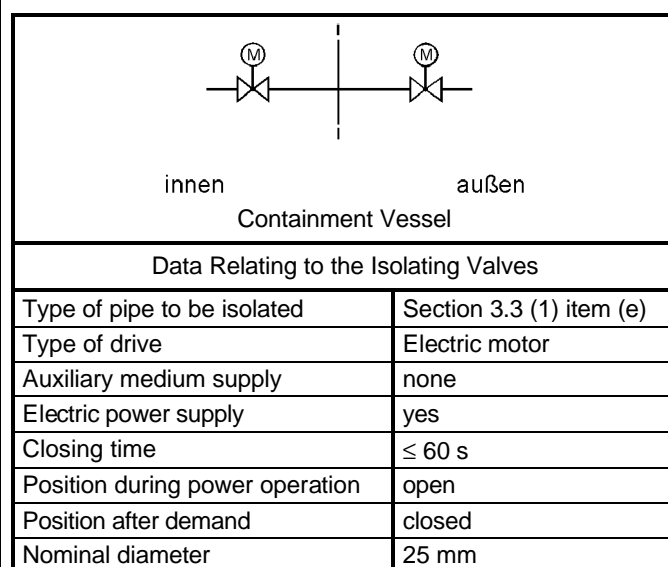

Fig. A-8: Example of an arrangement of isolating valves for the off-gas system of pressurized water reactors

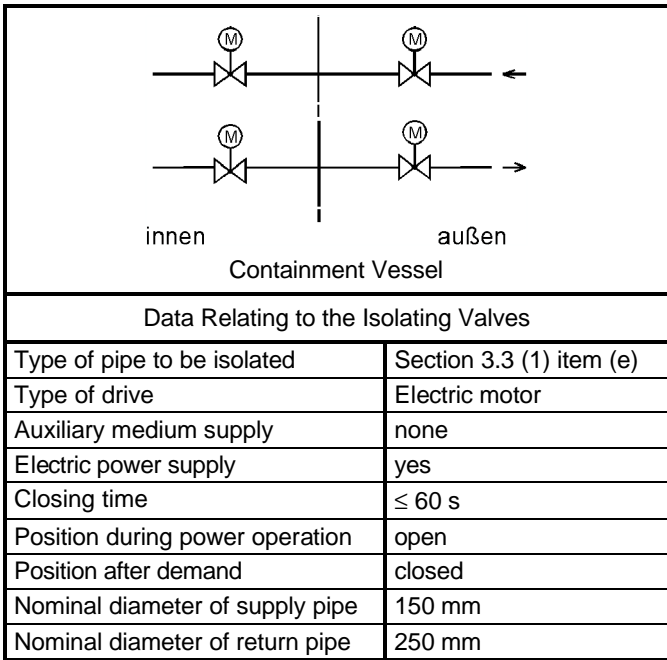

Fig. A-9: Example of an arrangement of isolating valves for the oil supply system of the reactor coolant pump of boiling water reactors

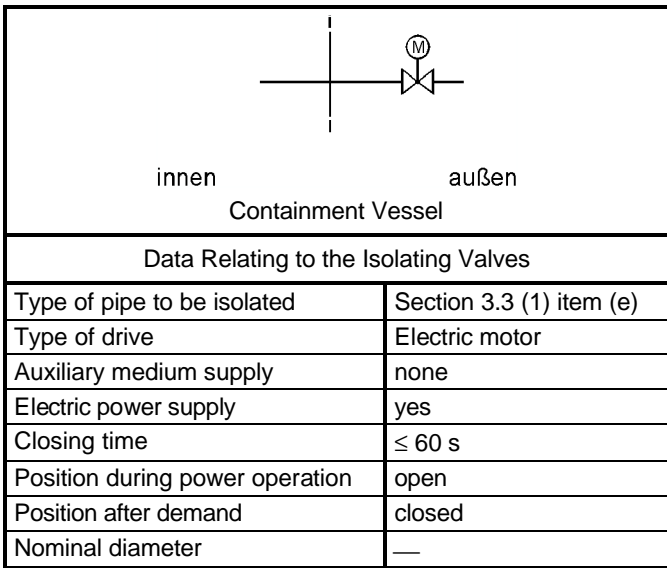

Fig. A-10: Example of an arrangement of isolating valves for a system located outside the containment vessel and designed to withstand the design pressure of the containment vessel

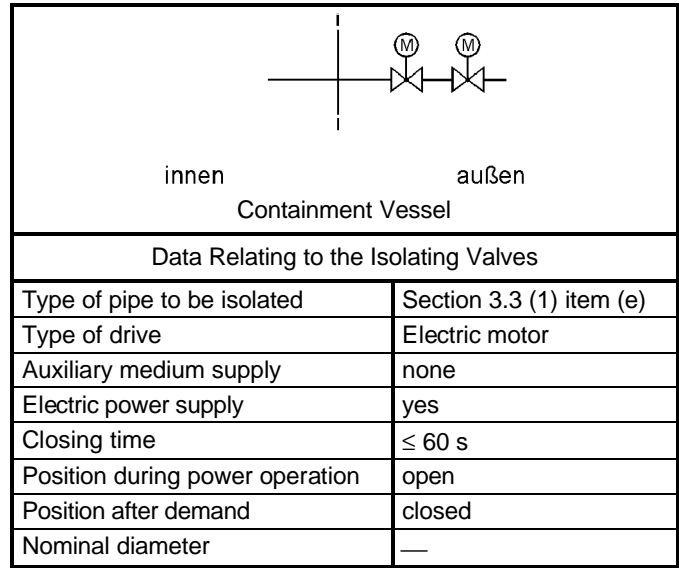

Fig. A-11: Example of an arrangement of isolating valves for a system located outside the containment vessel and not designed to withstand the design pressure of the containment vessel

Appendix B

Regulations Referred to in this Safety Standard

(The references exclusively refer to the version given in this annex. Quotations of regulations referred to therein refer to the version available when the individual reference below was established or issued.)

Atomgesetz		Act on the Peaceful Use of Atomic Energy and the Protection against its Hazards (Atomic Energy Act) dated 23 December 1959 (BGBl. I, p. 814) as published on 15 July 1985 (BGBl. I, 1985, No. 4, p. 1565), at last amended by law dated 19 August 2008 (BGBl. I, 2008, No. 40)
StrlSchV		Ordinance on the Protection against Damage and Injuries Caused by Ionizing Radiation (Radiological Protection Ordinance) dated July 20, 2001 (BGBl. I 2001, No. 38, p. 1714, as last amended by the ordinance of August 29, 2008 (BGBl. I, 2008, No. 40)
KTA 3405	(1979-02)	Integrated Leak Rate Test of. the Containment Vessel with the Absolute Pressure Method
KTA 3501	(1985-06)	Reactor Protection System and Monitoring Equipment of the Safety System
KTA 3504	(2006-11)	Electrical Drives of the Safety System in Nuclear Power Plants
DIN 31 051	(2003-06)	Fundamentals of maintenance